

PGA 25x31 Contact 604 Pin
Footprint:93

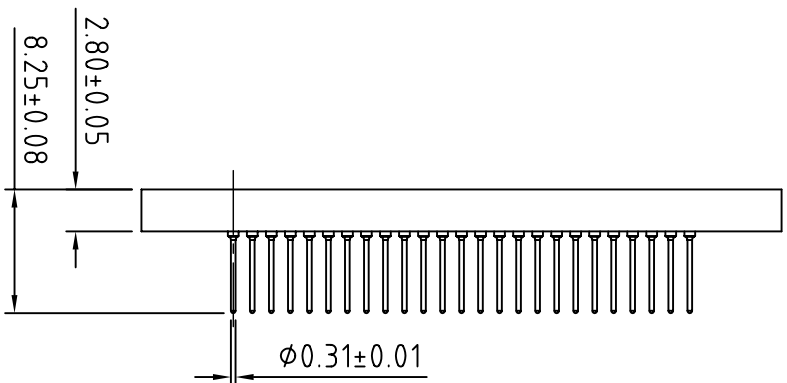

- Material**
- Pin : Brass,Screw Machined
 - Outer sleeve : CuZn38pb2
 - Inner Clip : Beryllium Copper,heat treated
 - (contact 6-finger)
 - Plating (Sleeve) : Tin plated over Brass & Nickel,
or 3u"Gold Plated over Brass
 - Plating (Clip) : Gold Flash Plated over Nickel
 - Special Plating : see table on "Pin & Clip Plated Code"
 - Insulator body : FR-4

- Electrical**
- Current rating :3Amps/contact max.
 - Contact resistance:≤4m Ω /contact
 - Insulation resistance:≥1KM Ω at V=100V
 - Operating Voltage:60 Vac/DC

- Mechanical**
- Average insertion force with steel pin of Ø0.31mm/.012": ≤ 60g
 - Average withdrawal force with steel pin of Ø0.31mm/.012": ≥ 20g
 - Mechanical life cycle: 200 time/minimum
 - Operating temperature(continuous) : Gold plated : -55°C to +125°C
Tin plated : -40°C to +105°C
 - Soldering temperature:+260°C,10s max.

- Features**
- Low insertion force socket. 6 fingers contacts
 - Closed end construction for 100% anti-wicking of solder.

UNIT:mm

| 修正REVISION | 日期 DATE | 說明 DESCRIPTION | PGA 25x31 Contacts:603 Pin L: 8.25mm |
|------------|---------|----------------|--------------------------------------|
| | | | |
| | | | |
| | | | |