



INTEGRATED TECHNOLOGY EXPRESS, INC.

# **IT8888F**

*PCI-to-ISA Bridge Chip*  
*(Code Name: Golden Gate)*

**Preliminary Specification V0.7.1**

Copyright © 1999 ITE, Inc.

This is Preliminary document release. All specifications are subject to change without notice. The material contained in this document supersedes all previous documentation issued for the related products included herein. Please contact ITE, Inc. for the latest document(s). All sales are subject to ITE's Standard Terms and Conditions, a copy of which is included in the back of this document.

ITE and IT8888F are trademarks of ITE, Inc.  
Intel and MISA (Moon ISA, 380AB) are claimed as trademarks by Intel Corp.  
PCI™ is a registered trademark of PCI Special Interest Group.  
All trademarks are the properties of their respective owners.  
All specifications are subject to change without notice.

Additional copies of this manual or other ITE literature may be obtained from:

ITE, Inc. **Phone:** (02) 2657-9896  
Marketing Department **Fax:** (02) 2657-8561, 2657-8576  
7F, No. 435, Nei Hu District, Jui Kuang Rd.,  
Taipei 114, Taiwan, R.O.C.

ITE (USA) Inc. **Phone:** (408) 530-8860  
Marketing Department **Fax:** (408) 530-8861  
1235 Midas Way  
Sunnyvale, CA 94086  
U.S.A.

ITE (USA) Inc. **Phone:** (512) 388-7880  
Eastern U.S.A. Sales Office **Fax:** (512) 388-3108  
896 Summit St., #105  
Round Rock, TX 78664  
U.S.A.

If you have any marketing or sales questions, please contact:

**Lawrence Liu**, at ITE Taiwan: E-mail: [lawrence.liu@ite.com.tw](mailto:lawrence.liu@ite.com.tw), Tel: 886-2-26579896 X6071,  
Fax: 886-2-26578561

**David Lin**, at ITE U.S.A.: E-mail: [david.lin@iteusa.com](mailto:david.lin@iteusa.com), Tel: (408) 530-8860 X238,  
Fax: (408) 530-8861

**Don Gardenhire**, at ITE Eastern USA Office: E-mail: [don.gardenhire@iteusa.com](mailto:don.gardenhire@iteusa.com),  
Tel: (512) 388-7880, Fax: (512) 388-3108

To find out more about ITE, visit our World Wide Web at:

<http://www.iteusa.com>

<http://www.ite.com.tw>

Or e-mail [itesupport@ite.com.tw](mailto:itesupport@ite.com.tw) for more product information/services.

### Revision History

Version	Date	Changes from Last Version
0.1	6/15/98	<ul style="list-style-type: none"> <li>Initial draft.</li> </ul>
0.2	7/10/98	<ul style="list-style-type: none"> <li>Implement Dell's requests. (5V power with 3.3V PCI) (add NOGO pin)</li> <li>Add Register design notes</li> </ul>
0.3	7/17/98	<ul style="list-style-type: none"> <li>Final Pin out from Design Engineer</li> <li>Fix typos.</li> <li>Enhance feature list</li> </ul>
0.4	9/9/98	<ul style="list-style-type: none"> <li>Update Register map</li> <li>Add PCI Configuration registers</li> </ul>
0.5	10/6/98	<ul style="list-style-type: none"> <li>Convert from IT8888F Advanced information v. 0.4</li> </ul>
0.6	11/24/98	<ul style="list-style-type: none"> <li>Add AC Characteristics and Waveforms</li> </ul>
0.7	1/21/99	<ul style="list-style-type: none"> <li>Chip Revision (Cfg_08&lt;7:0&gt;=8'h01)</li> <li>Change Power-On-Strap pins</li> <li>Change default value of Cfg_50h&lt;24:16, 5&gt; and Cfg_54h&lt;31&gt; to 1</li> <li>Change default value of Cfg_70h &amp; Cfg_74h as all zero</li> <li>Add Cfg_54h&lt;19:16&gt; to report IOCHCK# and I/O byte Enable Error to SERR#</li> <li>Add Cfg_54h&lt;21&gt; to mask IOCHCK# to SERIRQ encoding</li> <li>Add Cfg_54h&lt;20&gt; to select pin_133 as NOGO or CLKRUN#</li> <li>Change Cfg_54h&lt;30&gt; to patch unexpected DREQn de-assertion of PC/PCI DMA</li> <li>Change Cfg_50h&lt;1&gt; attribute as R/W</li> </ul>
0.7.1	04/23	<ul style="list-style-type: none"> <li>Chip Revision (Cfg_08&lt;7:0&gt;=8'h03)</li> <li>In the Retry/Discard Timers, Misc. Control Register table of Cfg_54h, the bit 20 description was changed to: Select the function of pin#133 to be NOGO or CLKRUN#</li> </ul>

## CONTENTS

Page

<b>1.</b>	<b>Features .....</b>	<b>1-1</b>
<b>2.</b>	<b>General Description.....</b>	<b>1</b>
<b>3.</b>	<b>Pin Configuration .....</b>	<b>3-1</b>
<b>4.</b>	<b>Pin Description .....</b>	<b>4-1</b>
<b>5.</b>	<b>Functional Description.....</b>	<b>5-0</b>
5.1	PCI Slave Interface .....	5-0
5.2	PCI Master Interface.....	5-0
5.3	PCI Parity.....	5-1
5.4	Positively Decode Spaces .....	5-1
5.5	Subtractive Decode .....	5-1
5.6	PC/PCI DMA (PPDMA) Slave Controller.....	5-1
5.7	Distributed DMA (DDMA) Slave Controller.....	5-2
5.8	Type-F DMA Timing .....	5-2
5.9	ISA Bus I/O Recovery Time.....	5-3
5.10	ISA Bus Arbiter .....	5-3
5.11	SMB Boot ROM Configuration .....	5-3
5.12	Serialized IRQ .....	5-5
5.13	NOGO and CLKRUN# .....	5-5
5.14	Optional FLASH ROM Interface.....	5-6
5.15	Testability .....	5-6
<b>6.</b>	<b>Register Description.....</b>	<b>6-1</b>
6.1	Configuration Register Map .....	6-1
6.2	Access Configuration Registers .....	6-2
6.3	Configuration Registers Description .....	6-4
6.3.1	Device/Vendor ID Register.....	6-4
6.3.2	Status / Command Register .....	6-4
6.3.3	Class Code/ Revision ID Register .....	6-6
6.3.4	Header Type/ Primary MLT/ Cache Line Size Register .....	6-7
6.3.5	Subsystem Device/Vendor ID Register .....	6-7
6.3.6	DDMA Slave Channel_1 Register / DDMA Slave Channel_0 Register .....	6-8
6.3.7	DDMA Slave Channel_3 Register / DDMA Slave Channel_2 Register .....	6-9
6.3.8	DDMA Slave Channel_5 Register / DMA Type-F Timing / PPD Register.....	6-10
6.3.9	DDMA Slave Channel_7 Register / DDMA Slave Channel_6 Register .....	6-11
6.3.10	ROM / ISA Spaces and Timing Control.....	6-12
6.3.11	Retry/Discard Timers, Misc. Control Register.....	6-16
6.3.12	Positively Decoded IO_Space_0 Register.....	6-18
6.3.13	Positively Decoded IO_Space_1 Register.....	6-19
6.3.14	Positively Decoded IO_Space_2 Register.....	6-19
6.3.15	Positively Decoded IO_Space_3 Register.....	6-20
6.3.16	Positively Decoded IO_Space_4 Register.....	6-20

6.3.17	Positively Decoded IO_Space_5 Register.....	6-21
6.3.18	Positively Decoded Memory_Space_0 Register.....	6-22
6.3.19	Positively Decoded Memory_Space_1 Register.....	6-22
6.3.20	Positively Decoded Memory_Space_2 Register.....	6-23
6.3.21	Positively Decoded Memory_Space_3 Register.....	6-23
6.3.22	Undefined Register.....	6-24
6.4	DDMA Slave Registers Description.....	6-25
<b>7.</b>	<b>Characteristic.....</b>	<b>7-1</b>
7.1	DC Electrical Characteristics.....	7-1
7.2	AC Characteristics.....	7-2
7.3	Waveforms.....	7-6
<b>8.</b>	<b>Package Information.....</b>	<b>8-1</b>
<b>9.</b>	<b>Ordering Information.....</b>	<b>9-1</b>

## FIGURES

	Page
Figure 2-1 IC Block Diagram.....	2-1
Figure 6-1 PCI Configuration Register Structure.....	6-2
Figure 6-2 PCI Configuration Access Mechanism #1.....	6-3
Figure 7-1 PCI Bus Interface Timing.....	7-6
Figure 7-2 PCI Configuration Write / Read Cycle.....	7-6
Figure 7-3 DEVSEL# Decoding Speed.....	7-7
Figure 7-4 PCI Memory Read from ISA device when Delayed Transaction is Disabled.....	7-7
Figure 7-5 PCI Memory Read from ISA device when Delayed Transaction is Enabled.....	7-8
Figure 7-6 IT8888F Initiated Refresh Cycle.....	7-9
Figure 7-7 PCI I/O Read from ISA device.....	7-9
Figure 7-8 PCI I/O Write to 8-bit ISA device when Cfg_54<28>=0b.....	7-10
Figure 7-9 PCI I/O Write to 16-bit ISA device when Cfg_54<28>=1b.....	7-10
Figure 7-10 PCI Memory Read from 8-bit ISA device.....	7-11
Figure 7-11 PCI Memory Read from 16-bit ISA device.....	7-11
Figure 7-12 PCI Memory Write to 8-bit ISA device.....	7-12
Figure 7-13 PCI Memory Write to 16-bit ISA device.....	7-12
Figure 7-14 DREQn/DACKn# Coding in PC/PCI DMA function.....	7-13
Figure 7-15 DMA Read Operation in PC/PCI DMA (Memory Access to PCI with TC).....	7-13
Figure 7-16 ISA Master Memory Read from PCI in PC/PCI DMA (Retried and Normal Termination).....	7-14
Figure 7-17 DMA Read Operation in DDMA (Memory Access to PCI when DDMA-Concurrent is Disabled.)... 7-15	7-15
Figure 7-18 DMA Read Operation in DDMA (Memory Access to PCI when both Delayed-Transaction and DDMA-Concurrent are Enabled.).....	7-16
Figure 7-19 DMA Write Operation in DDMA (Memory Access to PCI when both Delayed-Transaction and DDMA-Concurrent are Enabled.).....	7-17
Figure 7-20 ISA Master Write and Master-Initiated-Refresh Operation in DDMA (Memory Access to PCI when both Delayed-Transaction and DDMA-Concurrent are Enabled.).....	7-18
Figure 7-21 Serialized IRQ Coding.....	7-19
Figure 7-22 CLKRUN# Operation.....	7-19
Figure 7-23 SMB Serial E <sup>2</sup> PROM Configuration Programming.....	7-20
Figure 7-24 SMB Serial E <sup>2</sup> PROM Interface Timing.....	7-20

## TABLES

Page

---

Table 4-1 PCI Bus Interface Signals .....	4-1
Table 4-2 ISA Bus Interface Signals .....	4-3
Table 4-3 Miscellaneous Signals.....	4-6
Table 4-4 Power Signals.....	4-6
Table 4-5 IT8888F Alternative Pin Usage .....	4-7
Table 4-6 Power-On-Strap Settings .....	4-8
Table 6-1 IT8888F Configuration Register Map.....	6-1
Table 7-1. Recommended Operating Conditions.....	7-1
Table 7-2 General DC Characteristics.....	7-1
Table 7-3 DC Electrical Characteristics ( $T_{OPT}=0^{\circ}C\sim 70^{\circ}C$ , $VCC3=3.0\sim 3.6V$ , $VCC=4.75\sim 5.25V$ ).....	7-2
Table 7-4 AC Characteristics of PCI Interface Timing ( $VCC=5.0V\pm 5\%$ , $VCC3=3.3V\pm 5\%$ , $T_a=0^{\circ}C\sim 70^{\circ}C$ , $C_L=50pF$ ) unit: ns.....	7-2
Table 7-5 AC Characteristics of ISA Interface Timing (PIO Cycle) (Measured in Design Simulation) unit: 1T=1 PCICLK period $\geq 30ns$ .....	7-3
Table 7-6 AC Characteristics of ISA Interface Timing (DMA Cycle) (Measured in Design Simulation) unit: 1T=1 PCICLK period $\geq 30ns$ .....	7-4
Table 7-7 AC Characteristics of SMB Interface Timing (refer to Figure 7-23, Measured in Design Simulation) unit: $\mu s$ .....	7-5

## 1. Features

### ■ PCI Interface

- PCI Specification V. 2.1 compliant
- Supports 32-bit PCI bus & up to 33 MHz PCI bus frequency
- Supports PERR# & SERR# Error Reporting
- Supports Delayed Transaction
- Optional CLKRUN# interface support

### ■ Programmable PCI Address Decoders

- Supports either programmable positive decode or full subtractive decode of PCI cycles
- Provides 6 positively decoded I/O blocks & 4 positively decoded memory blocks.
- Optional support ROMCS# fast positive decoder

### ■ PC/PCI DMA Controller

- Comply with Intel Mobile PC/PCI DMA R2.2
- Supports PPDREQ# and PPDGNT#
- Provides software transparent capability

### ■ Distributed DMA Controller

- Comply with Distributed DMA R6.0
- Supports 7 DDMA channels
- Optional DDMA-Concurrent PCI bus

### ■ ISA Interface

- Supports full ISA compatible functions
- Supports ISA at ¼ of PCI frequency
- ISA Bus Master supported
- Supports 4 ISA slots

### ■ SM Bus

- Comply with System Management Bus Specification R. 1.0
- Supports single master mode
- Interface to Serial E<sup>2</sup>PROM

### ■ Power-on Serial Bus Configuration

- Power-on auto configuration through SM bus
- Patent pending on auto-start and auto-stop scheme

### ■ Serial IRQ

- Comply with Serialized IRQ Support for PCI system R6.0
- Supports both continuous and quite modes
- Auto detect Start Frame width and slot number
- Encodes all ISA IRQs and IOCHCK#

### ■ Optional FLASH ROM Interface

- Supports up to 1 Mbytes ROM size
- Positively fast decodes F-segments by power-on strapping

### ■ Versatile power-on strapping options

### ■ Supports NOGO function

### ■ Single 33 MHz Clock Input

### ■ +3.3V PCI I/F with +5V tolerant I/O buffers

### ■ +5V ISA I/F and core Power Supply

### ■ Package: 160-pin PQFP

## 2. General Description

The IT8888F is a PCI to ISA bridge single function device. The IT8888F serves as a bridge between the PCI bus and ISA bus. The IT8888F's 32-bit PCI bus interface is compliant with PCI Specification V2.1 and supports both PCI Bus Master & Slave. The PCI interface supports both programmable positive and full subtractive decoding schemes.

The IT8888F also integrates two enhanced DMA Slave controllers for achieving PCI DMA cycles: PC/PCI DMA Slave Controller & Distributed DMA Slave Controllers. The device also contains one SM bus (single master mode) which can be connected to a Serial E<sup>2</sup>PROM for automatic power-on configuration. ITE's proprietary (USA & Taiwan patent pending) power-on auto-configuration through

SM bus can provide customer with maximum design flexibility. The IT8888F also implements the optional fast positive decode of F, E, D, C memory segments. This special feature can provide a direct connection to an FLASH boot ROM.

The NOGO function which is also implemented in the IT8888F for enabling or disabling subtractive decode of PCI interface could be a software controlled output pin from other host controlled devices. The Serial IRQ is also implemented in the device for sending and receiving ISA IRQs & IOCHCK#. The device includes an ISA interface which supports full ISA compatible functions.

The IT8888F is available in 160-pin PQFP package.

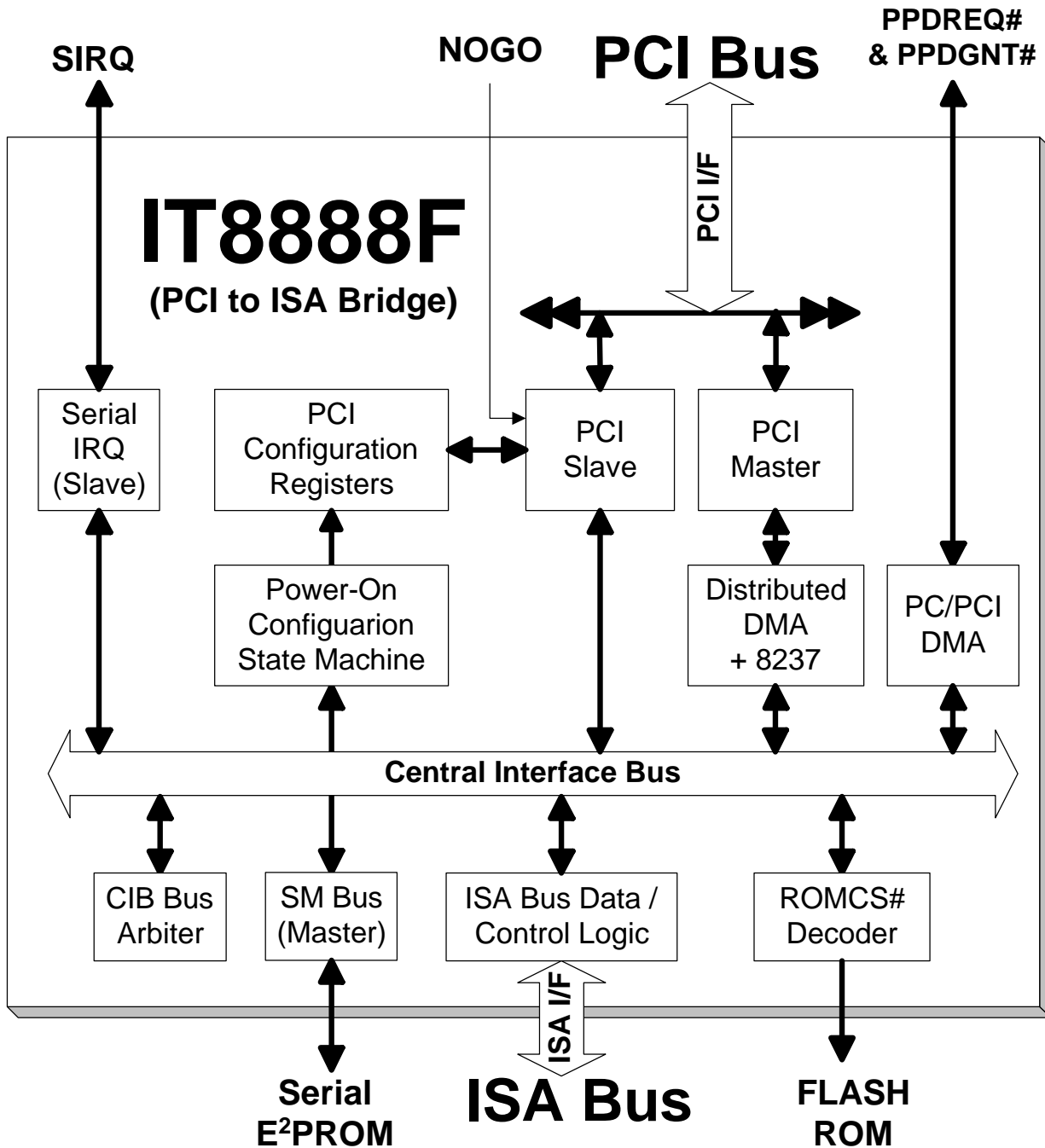
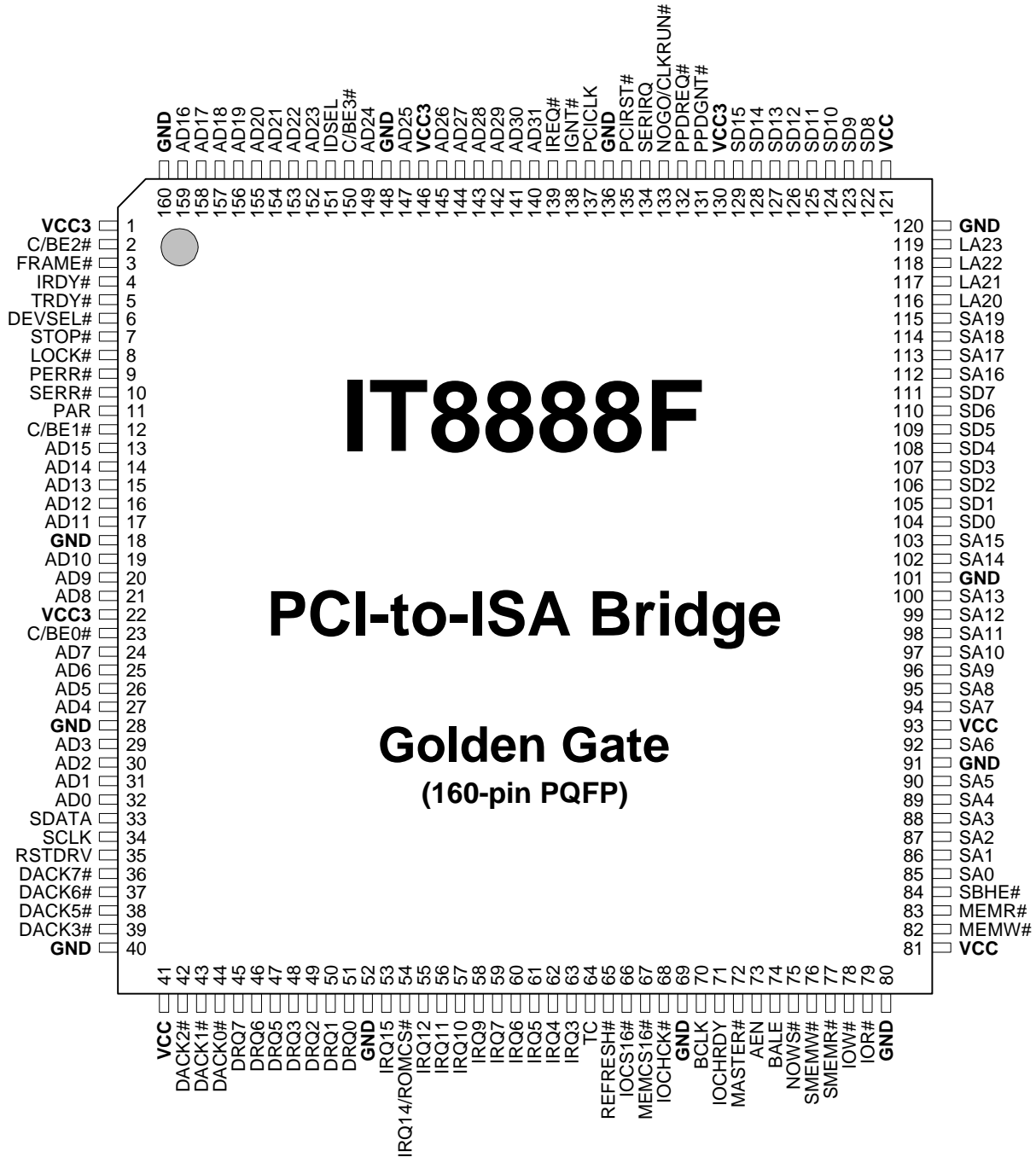

Figure 2-1 IC Block Diagram

### 3. Pin Configuration



#### 4. Pin Description

Table 4-1 PCI Bus Interface Signals

Pin #	Symbol	I/O	Description	Level												
140~145, 147, 149, 152~159, 13~17, 19~21, 24~27, 29~32	<b>AD[31:0]</b>	I/O	<p><b>PCI Multiplexed Address / Data 31 - 0.</b></p> <p>32-bit bi-directional address/data multiplexed lines. AD31 is the MSB and AD0 is the LSB. The direction of these pins are defined below:</p> <table border="0"> <tr> <td style="text-align: center;"><u>PHASE</u></td> <td style="text-align: center;"><u>Bus Master</u></td> <td style="text-align: center;"><u>Target</u></td> </tr> <tr> <td>Address Phase</td> <td>Output</td> <td>Input</td> </tr> <tr> <td>Read Data Phase</td> <td>Input</td> <td>Output</td> </tr> <tr> <td>Write Data Phase</td> <td>Output</td> <td>Input</td> </tr> </table>	<u>PHASE</u>	<u>Bus Master</u>	<u>Target</u>	Address Phase	Output	Input	Read Data Phase	Input	Output	Write Data Phase	Output	Input	3.3V
<u>PHASE</u>	<u>Bus Master</u>	<u>Target</u>														
Address Phase	Output	Input														
Read Data Phase	Input	Output														
Write Data Phase	Output	Input														
150, 2, 12, 23	<b>C/BE[3:0]#</b>	I/O	<p><b>Command/Byte Enable 3 - 0 #.</b></p> <p>Multiplexed bus command and byte enables.</p>	3.3V												
6	<b>DEVSEL#</b>	I/O	<p><b>Device Select #.</b></p> <p>When driven active low, the signal indicates the driving device has decoded its address as the target of the current access. This pin acts as an output pin when the IT8888F (including ISA slave) is the slave of PCI bus cycle transaction. Otherwise, it is an input pin.</p>	3.3V												
5	<b>TRDY#</b>	I/O	<p><b>Target Ready #.</b></p> <p>This signal indicates that the target of the current data phase of the transaction is ready to be completed. This pin acts as an output pin when the IT8888F (including ISA slave) is the slave of the PCI bus cycle transaction. Otherwise, it is an input pin.</p>	3.3V												
4	<b>IRDY#</b>	I/O	<p><b>Initiator Ready #.</b></p> <p>This signal indicates that the initiator is ready to complete the current data phase of the transaction. This pin acts as an output pin when the IT8888F is the bus master of the PCI bus. Otherwise, it is an input pin.</p>	3.3V												
3	<b>FRAME#</b>	I/O	<p><b>FRAME #.</b></p> <p>This signal is driven by the initiator to indicate the beginning and duration of a PCI access.</p>	3.3V												
151	<b>IDSEL</b>	I	<p><b>Initialization Device Select.</b></p> <p>This signal is used as a chip select during PCI Configuration read / write transactions.</p>	3.3V												

**Table 4-1 PCI Bus Interface Signals (Continued)**

Pin #	Symbol	I/O	Description	Level
11	PAR	I/O	<b>Parity</b> This signal is used for the even parity check on both AD[31:0] & C/BE[3:0]# lines. The PAR input/output direction follows the AD[31:0] input/output direction.	3.3V
9	PERR#	I/O	<b>Parity Error #.</b> This signal is used for reporting data parity errors during all PCI transactions, except in a Special Cycle. PERR# is an output when it detects a parity error in receiving data as a PCI Target or in reading data as a PCI Master.	3.3V
10	SERR#	I/OD	<b>System Error #.</b> This signal is used for reporting address parity errors, data parity errors on the Special Cycle command, or any other system error where the result will be catastrophic. (input for IC test only)	3.3V
8	LOCK#	I	<b>Lock #.</b> This signal indicates a Lock Cycle for an atomic operation that may require multiple transactions to complete.	3.3V
7	STOP#	I/O	<b>Stop #.</b> This signal indicates that the current target is requesting the initiator to stop the current transaction. This pin acts as an output pin when the IT8888F (including ISA slave) is the slave of the PCI bus cycle transaction. Otherwise, it is an input pin.	3.3V
139	IREQ#	I/O	<b>PCI Bus Request #.</b> This signal is asserted to request the host bridge to allow the IT8888F to become the PCI bus master. (DDMA) (input for IC test only)	3.3V
138	IGNT#	I	<b>PCI Bus Grant #.</b> This signal is asserted from the host bridge allowing the IT8888F to become the PCI bus master. (DDMA)	3.3V
132	PPDREQ#	I/O	<b>PC/PCI DMA (PPDMA) Request #.</b> This signal is used to encode the ISA DMA request information to the host bridge for PPDMA function. (input for IC test only)	3.3V
131	PPDGNT#	I	<b>PC/PCI DMA (PPDMA) Grant #.</b> This signal is asserted from the host bridge to send DACKn# information to IT8888F for PPDMA function.	3.3V
137	PCICLK	I	<b>33 MHz PCI Clock.</b>	3.3V
135	PCIRST#	I	<b>PCI Bus Reset #.</b> PCIRST# is used to reset PCI bus devices.	3.3V

**Table 4-2 ISA Bus Interface Signals**

Pin #	Symbol	I/O	Description	Level
115~112, 103, 102, 100~94, 92, 90~85	<b>SA[19:0]</b>	I/O	<b>ISA Address 19 - 0.</b> SA[19:0] are outputs except during the ISA master cycles.	5V
119 - 116	<b>LA[23:20]</b>	I/O	<b>ISA Latch Address 23 - 20.</b> Latchable Address bus LA23 to LA20 are outputs except during the ISA master cycles.	5V
84	<b>SBHE#</b>	I/O, P/U 50K	<b>System Byte High Enable #.</b> This signal indicates that the high byte on the ISA data bus is valid. SBHE# is an output except during the ISA master cycles	5V
129~122, 111~104	<b>SD[15:0]</b>	I/O, P/U 50K	<b>ISA Data 15 - 0.</b> 16-bit bi-directional data lines. SD15 is the MSB.	5V
79	<b>IOR#</b>	I/O, P/U 50K	<b>I/O Read #.</b> Active low output asserted by the CPU or DMA controller to read data or status information from the ISA device. Acts as input when ISA master cycles.	5V
78	<b>IOW#</b>	I/O, P/U 50K	<b>I/O Write #.</b> Active low output asserted by the CPU or DMA controller to write data or control information to the ISA device. Acts as an input during ISA master cycles.	5V
73	<b>AEN</b>	I/O, P/U 50K	<b>Address Enable.</b> This signal is used to indicate DMA accesses. This signal is also used as power-on strapping select.	5V
83	<b>MEMR#</b>	I/O, P/U 50K	<b>Memory Read #.</b> This signal is an output signal for all cycles except when the ISA master controls the bus.	5V
82	<b>MEMW#</b>	I/O, P/U 50K	<b>Memory Write #.</b> This signal is an output signal for all cycles except when the ISA master controls the bus.	5V

**Table 4-2 ISA Bus Interface Signals (Continued)**

Pin #	Symbol	I/O	Description	Level
66	<b>IOCS16#</b>	I, P/U 50K	<b>16-bit I/O Access #.</b> This signal indicates that the bus size of current ISA I/O slave is 16 bits.	5V
67	<b>MEMCS16#</b>	I/O, P/U 50K	<b>16-bit Memory Access #.</b> This signal indicates that the bus size of current ISA memory slave is 16 bits. During DMA/MASTER cycles, MCS16# is asserted low when memory target is on the PCI bus.	5V
75	<b>NOWS#</b>	I, P/U 50K	<b>No Wait States #.</b> This signal is asserted by the ISA slave in order to shorten the ISA cycle. The IT8888F samples NOWS# to escape standard wait states from the PCI when the ISA slaves have completed the transfer.	5V
71	<b>IOCHRDY</b>	I/O, P/U 50K	<b>I/O Channel Ready.</b> IOCHRDY is used by ISA slaves to insert wait states. During the ISA master cycles, IOCHRDY is asserted low by the IT8888F when the slave is on the PCI bus.	5V
72	<b>MASTER#</b>	I, P/U 50K	<b>16-bit Master #.</b> Indicates that a 16-bit ISA master takes control of the ISA bus.	5V
68	<b>IOCHCK#</b>	I, P/U 50K	<b>I/O Channel Check #.</b> ISA bus error indication	5V
65	<b>REFRESH#</b>	I/O, P/U 50K	<b>System Refresh Control #.</b> Output to ISA bus when converting system timer ticks into a refresh cycle. Input from ISA master is used to refresh on-board and slot DRAM.	5V
45~51	<b>DRQ[7~ 5, 3~0]</b>	I, P/D 50K	<b>DMA Request 7, 6, 5, 3, 2, 1, 0.</b> These active high input signals are used to indicate the DMA service request from DMA devices, or the ISA bus control request from the ISA master.	5V
36~39, 42~44	<b>DACK[7~ 5, 3~0]#</b>	I/O, P/U 50K	<b>DMA Acknowledge 7, 6, 5, 3, 2, 1, 0 #.</b> Active low outputs to acknowledge the corresponding DMA requests. (input for IC test only)	5V
64	<b>TC</b>	I/O, P/U 50K	<b>Terminal Count.</b> This signal is asserted to indicate the end of a DMA transfer. This signal is also used as power-on strapping select.	5V

**Table 4-2 ISA Bus Interface Signals (Continued)**

Pin #	Symbol	I/O	Description	Level
53	<b>IRQ15</b>	I, P/U 50K	<b>Interrupt Request 15.</b> This pin is the parallel interrupt request line 15.	5V
54	<b>IRQ14/ ROMCS#</b>	I/O, P/U 50K	<b>Interrupt Request 14 /ROM Chip Select #</b> The function selection of this pin is determined by ROM decoding related Configuration register settings. Please refer to section 5.14 Optional FLASH ROM Interface.	5V
55 - 63	<b>IRQ[12~9, 7~3]</b>	I, P/U 50K	<b>Interrupt Request 12, 11, 10, 9, 7, 6, 5, 4, 3.</b> These pins are the parallel interrupt request lines.	5V
35	<b>RSTDRV</b>	O	<b>ISA Reset.</b> A high level on this output resets the ISA bus. This signal asynchronously terminates any activity and places the ISA device in the reset state.	5V
77	<b>SMEMR#</b>	I/O, P/U 50K	<b>System Memory Read #.</b> This signal is an output signal for access under 1MB; otherwise, tri-state. (input for IC test only)	5V
76	<b>SMEMW#</b>	I/O, P/U 50K	<b>System Memory Write #.</b> This signal is an output signal for access under 1MB; otherwise, tri-state. (input for IC test only)	5V
70	<b>BCLK</b>	O	<b>Bus Clock</b> ISA bus clock equals to ¼ of PCI clock.	5V
74	<b>BALE</b>	I/O, P/U 50K	<b>Buffer Address Latch Enable</b> This signal is also used as power-on strapping select.	5V

**Table 4-3 Miscellaneous Signals**

Pin #	Symbol	I/O	Description	Level
133	<b>NOGO/ CLKRUN#</b>	I/O	<b>NOGO / Clock Run #</b> The function selection of this pin is determined by Cfg_54h<20>. When acting as NOGO, it is an input from chipset to disable the subtractive decode of the IT8888F; when acting as CLKRUN#, it is an input/output for the IT8888F to request PCICLK to keep running.	5V
134	<b>SERIRQ</b>	I/O	<b>Serial IRQ</b> This is Serialized IRQ for encoding parallel IRQ lines to one pin.	5V
33	<b>SDATA</b>	I/O, P/U 50K	<b>Serial Bus Data</b> System Management Bus data for Serial E <sup>2</sup> PROM.	5V
34	<b>SCLK</b>	I/OD, P/U 50K	<b>Serial Bus Clock</b> System Management Bus clock output for Serial E <sup>2</sup> PROM. (input for IC test only)	5V

**Table 4-4 Power Signals**

Pin #	Symbol	I/O	Description	Level
1, 22, 130, 146	<b>VCC3</b>	PWR	<b>PCI Interface Power Pins.</b> Those are connected to 3.3V power supply.	3.3V
41, 81, 93, 121,	<b>VCC</b>	PWR	<b>ISA Interface and chip core power pins.</b> 5V power pins.	5V
18, 28, 40, 52, 69, 80, 91, 101, 120, 136, 148, 160	<b>GND</b>	PWR	<b>Ground pins</b>	0 V

**Table 4-5 IT8888F Alternative Pin Usage**

Pin	Signal
1	VCC3
2	C/BE2#
3	FRAME#
4	IRDY#
5	TRDY#
6	DEVSEL#
7	STOP#
8	LOCK#
9	PERR#
10	SERR#
11	PAR
12	C/BE1#
13	AD15
14	AD14
15	AD13
16	AD12
17	AD11
18	GND
19	AD10
20	AD9
21	AD8
22	VCC3
23	C/BE0#
24	AD7
25	AD6
26	AD5
27	AD4
28	GND
29	AD3
30	AD2
31	AD1
32	AD0
33	SDATA
34	SCLK
35	RSTDRV
36	DACK7#
37	DACK6#
38	DACK5#
39	DACK3#
40	GND

Pin	Signal
41	VCC
42	DACK2#
43	DACK1#
44	DACK0#
45	DRQ7
46	DRQ6
47	DRQ5
48	DRQ3
49	DRQ2
50	DRQ1
51	DRQ0
52	GND
53	IRQ15
54	IRQ14/ROMCS#
55	IRQ12
56	IRQ11
57	IRQ10
58	IRQ9
59	IRQ7
60	IRQ6
61	IRQ5
62	IRQ4
63	IRQ3
64	TC
65	REFRESH#
66	IOCS16#
67	MEMCS16#
68	IOCHCK#
69	GND
70	BCLK
71	IOCHRDY
72	MASTER#
73	AEN
74	BALE
75	NOWS#
76	SMEMW#
77	SMEMR#
78	IOW#
79	IOR#
80	GND

Pin	Signal
81	VCC
82	MEMW#
83	MEMR#
84	SBHE#
85	SA0
86	SA1
87	SA2
88	SA3
89	SA4
90	SA5
91	GND
92	SA6
93	VCC
94	SA7
95	SA8
96	SA9
97	SA10
98	SA11
99	SA12
100	SA13
101	GND
102	SA14
103	SA15
104	SD0
105	SD1
106	SD2
107	SD3
108	SD4
109	SD5
110	SD6
111	SD7
112	SA16
113	SA17
114	SA18
115	SA19
116	LA20
117	LA21
118	LA22
119	LA23
120	GND

Pin	Signal
121	VCC
122	SD8
123	SD9
124	SD10
125	SD11
126	SD12
127	SD13
128	SD14
129	SD15
130	VCC3
131	PPDGNT#
132	PPDREQ#
133	NOGO/CLKRUN#
134	SERIRQ
135	PCIRST#
136	GND
137	PCICLK
138	IGNT#
139	IREQ#
140	AD31
141	AD30
142	AD29
143	AD28
144	AD27
145	AD26
146	VCC3
147	AD25
148	GND
149	AD24
150	C/BE3#
151	IDSEL
152	AD23
153	AD22
154	AD21
155	AD20
156	AD19
157	AD18
158	AD17
159	AD16
160	GND

**Table 4-6 Power-On-Strap Settings**

Symbol	Pin #	Jumper	Description
AEN	73	(P/Up)	Reserved for enabling chip test function when PCIRST#=0
		P/Down	IT8888F Normal Function
BALE	74	(P/Up)	Fast DEVSEL# timing for F-segment BIOS (both 000FXXXh and FFFFXXXh). It will set Cfg_50h<3>
		P/Down	No response or Subtractive Decode for F-segment access
TC	64	(P/Up)	Enable SM-bus Boot ROM Configuration. It will set Cfg_50h<4>, but will be auto-cleared when finishing download configure code.
		P/Down	Disable SM-bus Boot ROM Configuration

## 5. Functional Description

The IT8888F provides full ISA interface to hook up on PCI bus, so that the existing legacy ISA devices could be supported in new generation PC chipset architecture without ISA interface.

There are some sub-function blocks in the IT8888F as described below:

### 5.1 PCI Slave Interface

The IT8888F PCI Slave interface provides some positively decode space:

- IT8888F PCI configuration register spaces – positively decode w/ medium DEVSEL# speed on the Type0 PCI configuration cycle, the access space is described in 6.2 Access Configuration Registers on page 6-2.
- Six I/O positively decode spaces – defined in IT8888F Configuration Registers: Cfg\_58h ~ Cfg\_6Fh.
- Four Memory positively decode spaces – defined in IT8888F Configuration Registers: Cfg\_70h ~ Cfg\_7Fh.
- Optional I/O Port 80 Write Snooping.
- Optional F-segment BIOS claim w/ Fast DEVSEL# speed.
- ISA Palette decoding (ref: Cfg\_50h<7:6>).
- DDMA registers spaces.
- PC/PCI DMA cycle space: I/O addresses of 0000h / 0004h / 00C0h / 00C4h.

The IT8888F supports PCI 2.1 Delayed Transaction feature which can be enabled / disabled by programming Cfg\_50h<1>. The benefit of Delayed Transaction is that the PCI bus is still available and can be used by other PCI master, even when there is an ISA PIO cycle in progress behind IT8888F.

When Delayed Transaction is enabled, the IT8888F will retry the PCI-to-ISA cycle claimed by IT8888F and latch those address / command / byte-combination, and issues ISA cycle. When the ISA site is not finished, the PCI Slave interface of IT8888F will still retry any PCI cycle. Once the ISA cycle is finished, the PCI Slave interface will wait the same PCI cycle (same address / command / Byte-enable) and terminate it normally with TRDY# asserted. But before that, the other PCI cycle with different address or command or Byte-enable still will be retried.

If the original PCI bus master after retried never issue the same cycle within the programmed DISCARD Timer, then the IT8888F will discard that ISA transaction, so that the IT8888F is able to respond to other PCI transactions without locking its ISA bus interface. Please refer to the Cfg\_54h<15:8> in 6.3.11, the Retry/Discard Timers of the Misc. Control Register on page 6-16 for the setting of Discard Timer. There is an option to report System Error via asserting SERR#.

The IT8888F also supports Exclusive access via LOCK# control. Please refer to PCI Specification Revision 2.1, for more detailed description.

### 5.2 PCI Master Interface

The IT8888F will issue PCI cycle for ISA bus master cycle and DDMA memory cycle if those accesses are forwarded to PCI bus. The Cfg\_50h<23:12> define the decoding spaces for IT8888F to decide forwarding the access of ISA bus master or DDMA controller to PCI bus or not.

When the accessed space is forwarding to PCI bus, the IT8888F will assert IREQ# to PCI bus arbiter if the DACKn# source is DDMA. Once the IGNT# is asserted by PCI arbiter and the PCI bus is in idle state, the PCI Master I/F of IT8888F will issue non-burst PCI Memory Read/Write cycles or PCI I/O Read/Write cycles (if Cfg\_50h<23>=1). In the mean time, the IOCHRDY will be de-asserted to insert wait-state until forwarding cycle is finished on PCI site.

When in PC/PCI DMA (PPDMA) cycle, the DACKn# is decoded from PPDGNT#, and the IT8888F will not issue IREQ#. As long as the PPDGNT# and MASTER# signal are asserted and there exist an ISA command

issued by ISA master, then the PCI Master I/F of IT8888F will issue a PCI cycle for ISA master if the accessed space is located on PCI bus.

Whenever the PCI Master I/F of IT8888F is retried, it will release PCI bus ownership and re-arbitrate and re-issue the same transaction. But if the same retry occurs too many times and exceeds the Retry Timer limitation, then the PCI Master I/F will stop trying and there is an option to report System Error via asserting SERR#. Please refer to Cfg\_54h<7:0> in 6.3.11 Retry/Discard Timers, Misc. Control Register on page 6-16 for more detailed Retry Timer setting.

### 5.3 PCI Parity

The IT8888F, like other standard PCI devices, can handle parity error and other errors. Whenever the IT8888F detects address parity error, it is able to assert SERR# if the SERR# reporting mechanism is enabled in PCI Command/Status register.

Also when IT8888F acts as a PCI slave, it will check the data parity of writing in data; when IT8888F acts as a PCI master, it will check the data parity of reading back data. Once it detects a data parity error, it can report data parity error and assert PERR# if the PERR# reporting mechanism is enabled in PCI Command/Status register.

### 5.4 Positively Decode Spaces

The six positively decode I/O spaces can be programmed to claim PCI I/O cycle with Fast / Medium / Slow / Subtractive DEVSEL# timing speed. In addition, the ISA I/O aliases can be set to support legacy ISA card with non-fully decoded (only decodes with XA9~0). In other words, when alias is enabled for one I/O space, then the addresses A15~A10 of the PCI access address will be ignored for the enabled I/O space. All I/O spaces are limited under 64KB I/O size. IT8888F only claims I/O access with PCI address A[31:16]=0000h. When programmed to subtractive decoding speed, IT8888F will claim PCI I/O access only when whole chip Subtractive decode function is enabled (Cfg\_50h<0>).

The four positively decode Memory spaces can also be programmed to claim PCI Memory cycle with Fast / Medium / Slow / Subtractive DEVSEL# timing speed. The memory space is not limited, i.e., even above ISA 16MB size, if it falls into IT8888F Memory positive decoding spaces, then it will be forwarded to ISA bus with address A31~A24 ignored. So users must carefully claim memory spaces, since the mechanism can support memory relocation. When programmed to subtractive decoding speed, IT8888F will claim PCI Memory access only when whole chip Subtractive decode function is enabled (Cfg\_50h<0>), but the claimed space is restricted under memory space base/size setting, not limited to 16MB size.

### 5.5 Subtractive Decode

IT8888F supports subtractive decode. In general, the subtractive decode mechanism of PCI-to-PCI Bridge chip is to respond to all non-claimed space. But for IT8888F, avoiding ISA space wrapped, it only responds to the memory space under 16MB size (ISA only has 24-bit addressing ability) when processing subtractive decode, except when the access space is hit to one of four positively decode memory space with slowest DEVSEL# timing speed. And the IT8888F only responds to unclaimed PCI I/O space under 64KB.

### 5.6 PC/PCI DMA (PPDMA) Slave Controller

The IT8888F, following the “ Mobile PC/PCI DMA Arbitration and Protocols MHPG Architecture Functional Architectures Specification” by Intel Corporation, Revision 2.2, builds a PC/PCI DMA (PPDMA) Slave which supports all 7 ISA DMA channels through a single PPDREQ# / PPDGNT# pair. It provides a very low cost, low pin count mechanism. Please check the waveform for more details.

This protocol works as follows: the IT8888F encodes the DMA channel request information on the PPDREQ# line and decodes the PPDGNT#, which is output from PPDMA Host (in chipset), to assert the DACKn# of the granted DMA channel to ISA bus.

The PPDMA protocol supports Single DMA, Demand DMA, but not Block DMA, nor software request DMA

transfers.

For PPDMA transfer, the PPDMA Host will separate Memory transaction portion from DMA operation, and issues PCI I/O transaction to PPDMA Slave with PPDGNT# asserted and special address listed below:

PCI I/O Address	R/W	IT8888F Operation
00h	R/W	Normal DMA operation without TC
04h	R/W	Normal DMA operation with TC
C0h	R	DMA Verify operation without TC
C4h	R	DMA Verify operation with TC

The IT8888F PPDMA slave controller can handle the PCI Retry while it was granted the bus, it continues to hold DACKn# active to ISA bus even when the PPDGNT# is removed. Also when the PCI Master I/F of IT8888F issues cycle for ISA Master and is retried, PPDMA slave would re-send the PPDREQ# to advise PPDMA Host to process Passive Release.

### 5.7 Distributed DMA (DDMA) Slave Controller

The IT8888F integrates two DMA controllers (8237) to build a 7-channel DDMA slave for DDMA function, which comply with Distributed DMA Specification R6.0.

There are seven DMA channels in IT8888F. Each channel maps to different ISA DMA channel, i.e. DMA channel 7~5, 3~0. Each channel can be treated as a separate DDMA slave, which has its own DDMA channel base address and can be enabled / disabled separately.

To achieve compatibility with ISA, the DDMA channel 7~5 are fixed at 16-bit transfer width; the DDMA channel 3~0 are fixed at 8-bit transfer width. Each channel supports 24 or 32 bits addressing. That is to say, with IT8888F, the system OS or drivers can perform DMA operation to/from anywhere in 4GB-memory space, and is free from the limit of ISA 16MB memory space. When not using the high page register, the system OS or drivers either write 00h or disable high page for dedicated channel.

In PC system, the DDMA Host is located in chipset, and it converts the address and data of legacy DMA accesses (including transferring base address, word counter register, mode / command / mask /... registers in I/O port 00h~1Fh, C0h~DFh and page registers in I/O port 8Xh~9Xh). This enables the IT8888F will receive PCI I/O cycles with the address = programming register offset plus pre-configured Base Address of dedicated DDMA slave channel. Please refer to 6.4 DDMA Slave Registers Description on page 6-25 for DDMA Slave Register mapping. For detailed register descriptions of legacy DMA controller, there are numerous manufactures' data books that describe the functionality.

### 5.8 Type-F DMA Timing

The IT8888F also supports Type F DMA timing. Each DMA channel can be programmed to operate in normal DMA timing or Type-F timing. For normal timing, the DDMA controller issuing I/O and Memory commands or the PPDMA module issuing the DMA I/O command meet the DMA operating timing defined in ISA Specification (IEEE P996 draft). Since the system memory bus is located behind ISA bus in legacy IBM PC/AT architecture, the timing is very loose (slow). But for current PC architecture, the system memory is located on Host bridge chip (or PCI North Bridge), thus DMA cycles can be operated faster to achieve better ISA DMA performance.

### 5.9 ISA Bus I/O Recovery Time

The recovery time of back to back ISA I/O cycles is 1.5 BCLK (ISA System bus clock). The IT8888F provides different I/O recovery time setting for 8-bit I/O cycles and 16-bit I/O cycles.

The configured 8-bit I/O recovery time is inserted after ISA I/F finishes the 8-bit I/O cycle, and the configured 16-bit I/O recovery time is inserted after ISA I/F finishes the 16-bit I/O cycle. No additional recovery time will be inserted due to byte conversion (PCI I/O cycle could be 8/16/24/32 bits, but ISA I/O is only 8/16 bits).

### 5.10 ISA Bus Arbiter

The IT8888F internal ISA arbiter will handle and exclude DDMA cycle, Refresh cycle and PIO cycle from PCI bus to optimize the ISA bus utilization.

To achieve PCI/ISA concurrency, there are some technologies to improve system performance: Delayed Transaction, Passive Release and the "DDMA-Concurrent" in the IT8888F design.

In legacy PC architecture, the CPU and PCI bus are held throughout the whole DMA operation even when the DMA access space is onto ISA bus or when the forwarded PCI transaction requires just a few PCI clocks to complete. IT8888F provides one option: DDMA-Concurrent cycle when DDMA operation (Cfg\_54h<31>). When enabled, the IT8888F will request PCI bus only when DDMA controller or ISA master issued a transaction to be forwarded to PCI bus, and the IT8888F will release PCI bus after it finished PCI bus cycle, even when the DDMA / ISA master still occupies ISA bus.

This is achieved by ISA arbiter, whenever DDMA occupy ISA bus, the PCI Slave will retry all PCI cycles belonging to IT8888F, so that the PCI bus can be used by other PCI transactions.

The ISA Bus Refresh timer requests ISA memory REFRESH operation every 15.36 $\mu$ s which is divided from PCI clocks by 512. The refresh module could be disabled by clearing Cfg\_54h<26>.

### 5.11 SMB Boot ROM Configuration

In addition that the IT8888F configuration can be done by PCI Configuration cycles through system chipset, the IT8888F also offers an optional configuration method via the System Management Bus (SMB, similar to I<sup>2</sup>C BUS) Boot ROM. As the current version of IT8888F only supports single master mode, users are prohibited to connect the IT8888F SMB interface to other system SMB bus. Only Serial E<sup>2</sup>PROM can be connected, and the preset slave address is 1010000b.

The Serial E<sup>2</sup>PROM Data is grouped by each five bytes into the 1<sup>st</sup> byte, which serves as an index to indicate which PCI Configuration register is. The other 4 bytes are the 32-bits data will be written to the indexed register.

SMB ROM Data format in Serial E<sup>2</sup>PROM is illustrated below:

ROM Address	ROM Data	IT8888F Operation
top		
5n	Index = AAh	Stop
5m+4	Data	Cfg_50h<31:24>
5m+3	Data	Cfg_50h<23:16>
5m+2	Data	Cfg_50h<15:8>
5m+1	Data	Cfg_50h<7:0>
5m	Index = 50h	Cfg_50h
6	Data	Cfg_XXh<7:0>
5	Index = XXh	Cfg_XXh
4	Data	Cfg_??h<31:24>
3	Data	Cfg_??h<23:16>
2	Data	Cfg_??h<15:8>
1	Data	Cfg_??h<7:0>
0	Index = ??h	Cfg_??h

Whether the chip will execute SMB Boot ROM Configuring Sequence or not is determined by one power-on-strap setting. Please refer to the Table 4-6 Power-On-Strap Settings on page 4-8. If SMB boot ROM Configuration is enabled, the IT8888F will then set the SMB\_In\_Progress status bit (Cfg\_50h<4>) on page 6-12 and begin to issue the I<sup>2</sup>C Sequential Read Operation. It writes to PCI Configuration Registers after it has finished reading every five bytes from SM ROM. If it reads an Index value as AA<sub>hex</sub>, then it will stop I<sup>2</sup>C Sequential Read Operation and clear the SMB\_In\_Progress status bit. The system BIOS can monitor the status bit to see if SMB is in progress before BIOS can decide to enable some computer system sub-functions.

Conversely, if SMB boot ROM Configuration is disabled in power-on-strap setting, the IT8888F will then clear the SMB\_In\_Progress status bit, and no I<sup>2</sup>C Sequential Read Operation occurs.

For instance, if users intend to claim a Memory space of 00F3XXX<sub>h</sub> (64KB size) and one I/O space of 02AC<sub>h</sub> ~ 02AD<sub>h</sub> (2byte size) for a special ISA card (or users try to hook up the ISA device to PCI bus), a Serial E<sup>2</sup>PROM can be programmed. The resulted data are listed on the next page:

Serial E <sup>2</sup> PROM		IT8888F Configuration Register
Address	Data	
top ~ B	XX <sub>h</sub>	
A	<b>AA<sub>h</sub></b>	IT8888F SMB I/F Stop
9	C1 <sub>h</sub>	Cfg_64h<31:24> Medium DEVSEL#, 2Byte size
8	00 <sub>h</sub>	Cfg_64h<23:16> = reserved
7	02 <sub>h</sub>	Cfg_64h<15:0> = 02AC <sub>h</sub>
6	AC <sub>h</sub>	
5	64 <sub>h</sub>	Index 64 <sub>h</sub> => Cfg_64h
4	A2 <sub>h</sub>	Cfg_7Ch<31:24> Slow Medium, 64KB size
3	00 <sub>h</sub>	Cfg_7Ch<23:0> = 00F3XXXX <sub>h</sub>
2	F3 <sub>h</sub>	
1	00 <sub>h</sub>	
0	7C <sub>h</sub>	Index 7C <sub>h</sub> => Cfg_7Ch

In the example above, the IT8888F SMB Configuration block will write the 32-bit data of A200F300<sub>h</sub> to Cfg\_7Ch when it finishes reading byte 0~4 of Serial E<sup>2</sup>PROM. It will also write the 32-bit data of C10002AC<sub>h</sub> to Cfg\_64h when it finishes reading byte 5~9 of Serial E<sup>2</sup>PROM. After it receives an AA<sub>h</sub> in the ROM position of 5xN (i.e. address of 5<sub>d</sub>, 10<sub>d</sub>, 15<sub>d</sub>, .. etc.), the SMB I/F stops fetching more data and clear the SMB\_In\_Progress status bit.

For detailed SMB Configuration operation, please refer to the “IT8888F SMB Configuration Programming Guide”.

The SMB Boot Configuring mechanism is patent pending.

## 5.12 Serialized IRQ

The IT8888F builds a Serialized IRQ slave which complies with Serialized IRQ Support for PCI system R6.0.

The Serialized IRQ slave provides signal filtering and encoding logic for all ISA IRQ channels (IRQ [15:14, 12:9, 7:3] and IOCHCK#), which also supports both continuous and quite mode, and auto detect Start Frame width and slot number.

## 5.13 NOGO and CLKRUN#

The IT8888F also supports NOGO function, which is MUX-ed with the CLKRUN# signal (selected by Cfg\_54h<20>).

The NOGO is an input and controlled by chipset to disable the subtractive decode mechanism of the IT8888F, since there is only one subtractive decode device present on PCI bus. For short term, system manufacturers may use GPIO of chipset to control the NOGO pin of the IT8888F to boot up system, but the IT8888F also provides a mechanism to turn on/off the subtractive decode. And it will not be affected by DMA operation, nor by Delayed transaction.

The IT8888F supports CLKRUN# function to reduce system power consumption when no PCI activity in progress. The CLKRUN# function follows the protocol defined in PCI Mobile Design Guide, Revision 1.0. But since the ISA system clock is divided from PCICLK, if some ISA cards still need ISA bus clock all the time, then the user should leave the Cfg\_54<27> stay on default value of one. Thus the IT8888F will monitor system CLKRUN# signal and keep PCICLK running; otherwise, the IT8888F will only claim CLKRUN# when ISA Master / DMA requests service or for the DMA service duration, or when the Serialized IRQ module detects the status change on any ISA interrupt requests.

#### 5.14 Optional FLASH ROM Interface

The IT8888F provides ROM decoding and write protect. The ROM chip select can be decoded by programming versatile Cfg\_50h<31:24> settings through segments C to F under 1MB and the top 1MB of 4GB. The ROM decoding logic provides ROMCS# signal (which is shared with IRQ14 signal, selected by the internal logic, i.e., when the ROM decoding related Configuration register settings are enabled, the pin 54 will be ROMCS# output automatically; otherwise, it will be IRQ14 input). The PCI Slave I/F needs to claim PCI memory space either by configuring four positively decoding spaces or by setting IT8888F in the subtractive decode mode, except in the power-on-strap settings: F-segment setting (BALE).

If F-segment is set as positively decode, the IT8888F will only do fast DEVSEL# decoding speed and ROMCS# is generated automatically. Its space is F-segment of both 1MB top and 4GB top. Once the ROM is not on ISA interface, the IT8888F will disable F-segment fast decoding itself.

#### 5.15 Testability

The IT8888F provides several test modes, which are aimed for chip testing, not for system testing.

Test Mode	PCIRST#	AEN	DRQ1	DRQ0
Normal Operation	1	X	X	X
	0	0	X	X
	0	1	0	0
Tri-State Test	0	1	0	1
NAND Chain Test	0	1	1	0
Reserved	0	1	1	1

##### Tri-State Test:

This test mode tri-states all outputs and bi-directional buffers, including the NAND chain outputs, BCLK and RSTDRV.

##### NAND Chain Test:

The IT8888F builds the NAND Chain test mode. This test mode tri-states all outputs and bi-directional buffers, except for BCLK and RSTDRV, and all the other output buffers are configured as inputs in NAND Chain test mode and are included in the NAND chain. The first input of the NAND chain is DACK2#. The NAND chain is routed counter-clockwise around the chip (e.g., DACK2#, DACK1#, DACK0#, DREQ7,...). The BCLK is an intermediate output, and the RSTDRV is the final output. PCIRST#, AEN, DRQ1, DRQ0, BCLK and RSTDRV pins are not included in the NAND chain. This testing method can be used to verify chip package connectivity,  $V_{IH}/V_{IL}$  DC characteristics.

## 6. Register Description

### 6.1 Configuration Register Map

The IT8888FF PCI header configuration register set complies with Type 00h Configuration Space Header described in the PCI Specification R. 2.1.

**Table 6-1 IT8888F Configuration Register Map**

31	16	15	00	Index
Device ID (8888h)		Vendor ID (1283h)		00h
Status		Command		04h
Base Class Code (06h)	Sub-class code(01/80h)	Programming I/F (00h)	Revision ID (01h)	08h
Reserved (00h)	Header Type (00h)	Latency Timer (00h)	Cache Line Size (00h)	0Ch
Reserved				10h~2Bh
Subsystem Device ID (0000h)		Subsystem Vendor ID (0000h)		2Ch
Reserved				30~3Fh
DDMA Slave Channel_1 Register		DDMA Slave Channel_0 Register		40h
DDMA Slave Channel_3 Register		DDMA Slave Channel_2 Register		44h
DDMA Slave Channel_5 Register		DMA Type F Timing	PC/PCI DMA Control	48h
DDMA Slave Channel_7 Register		DDMA Slave Channel_6 Register		4Ch
ROMCS#	Master/DMA access	MTOP, I/O Recovery	Timing Control	50h
Misc. Control	Reserved	Discard Timer	Retry Timer	54h
Positively Decoded I/O_Space_0				58h
Positively Decoded I/O_Space_1				5Ch
Positively Decoded I/O_Space_2				60h
Positively Decoded I/O_Space_3				64h
Positively Decoded I/O_Space_4				68h
Positively Decoded I/O_Space_5				6Ch
Positively Decoded Memory_Space_0				70h
Positively Decoded Memory_Space_1				74h
Positively Decoded Memory_Space_2				78h
Positively Decoded Memory_Space_3				7Ch
Reserved				80h~FFh

**6.2 Access Configuration Registers**

The IT8888F will respond to all PCI Bus Configuration cycles when the IDSEL input is asserted high. Address bits 1-0 of the Configuration cycle are both zeros and address bits 10-8 correspond to internal functions.

The Type0 configuration address format is as follows:

AD31-11	AD10-8	AD7-2	AD1-0	C/BE3-0#
Only one asserted to active IDSEL	Function Select, IT8888F only respond to Function = 000b	Register Select, to select one double-word register	Configuration Type, IT8888F only response to Type = 00b	Byte Select, to select one or more byte in selected double-word register

The configuration registers can be accessed as byte, word (16 bits) or Double-Word (32 bits) quantities or any byte combination. In all of these accesses, only byte enables are used, AD[1:0] is always 00b when accessing the configuration registers. All multi-byte fields use "little-endian" ordering (that is, lower addresses contain the least significant parts of the fields). Registers that are marked "Reserved" will be decoded and return zeros when read. All bits defined as "Reserved" within IT8888F's PCI Configuration Registers will be read as zero and will be unaffected by writes, unless specifically documented otherwise.

The software can use the PCI Configuration Mechanism One to read or write the IT8888F PCI configuration register space. The PCI Configuration Mechanism One utilizes two 32-bit I/O ports located at addresses 0CF8h and 0CFCh. These two ports are:

1. **INDEX Port:** 32-bit wide, occupying I/O address 0CF8h through 0CFBh.
2. **DATA Port:** 32-bit wide, occupying I/O address 0CFCh through 0CFFh.

**Figure 6-1 PCI Configuration Register Structure**

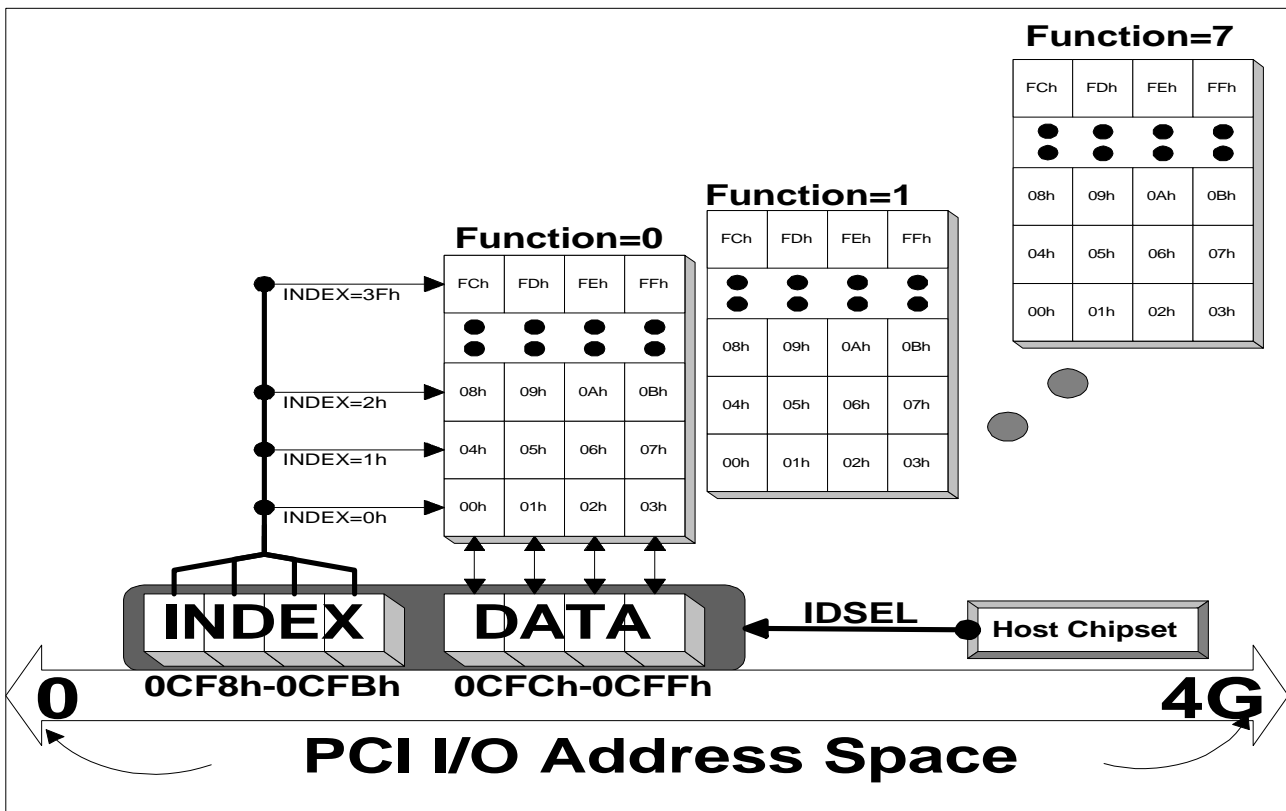

Accessing any PCI configuration register is a two step process:

Step 1: Perform I/O writes of the bus number, physical device number, function number, and register index number to the PCI Configuration Mechanism One INDEX Port. (The mother board chipset will decode the bus number, device number and then generate the IDSEL signal to select the device. The device then decodes the function number to select which bank of register to be accessed and decodes the register index number to select which double-word register will be accessed.)

Step 2: Perform an I/O read from or write to the PCI Configuration Mechanism One DATA Port. The PCI Configuration Mechanism One INDEX & Data Port format is illustrated below:

**Figure 6-2 PCI Configuration Access Mechanism #1**

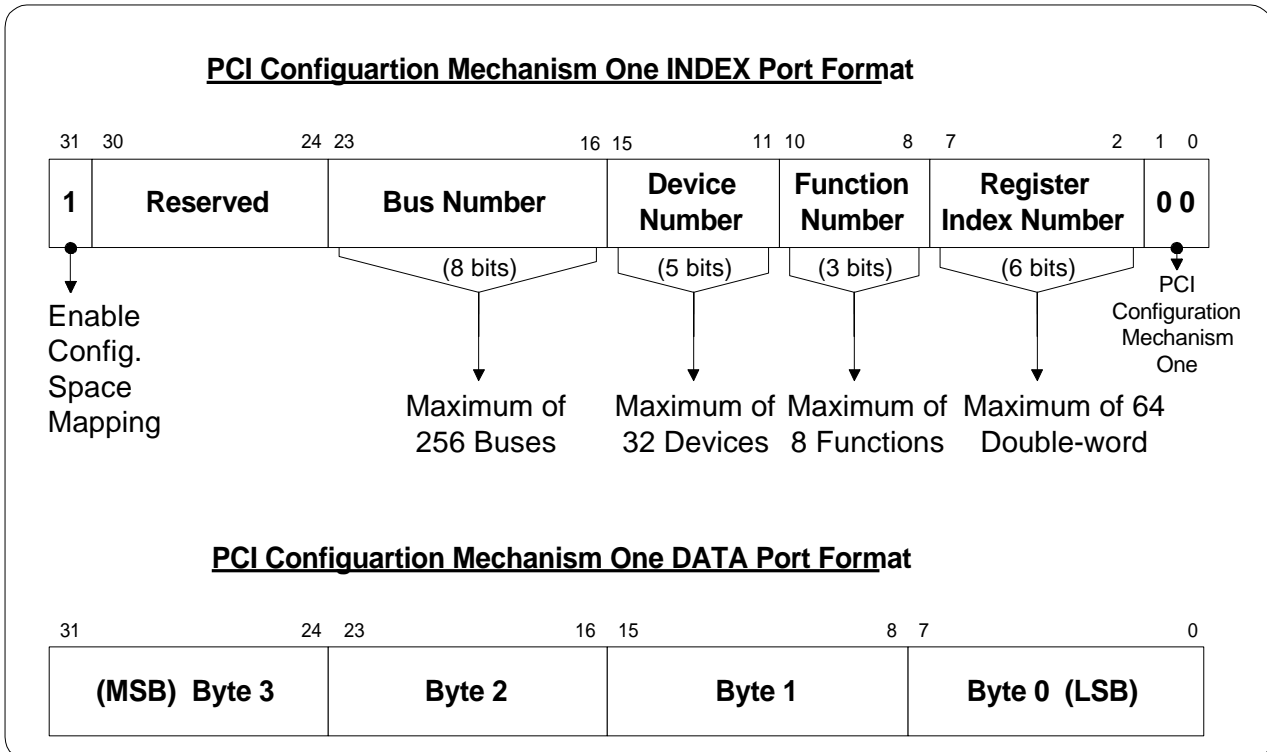



Cfg_04h		Status / Command Register	
<15:10>	RO	Reserved	all zero
<9>	RO	Fast back-to-back control. IT8888F will not perform FBTB access to the target on PCI bus.	0b
<8>	R/W	SERR# drives low enable. A value of 1 enables IT8888F to drive SERR#. A value of 0 disables SERR# signal.	0b
<7>	RO	AD bus stepping. IT8888F does not perform AD stepping.	0b
<6>	R/W	Parity error response. When the bit is 0, IT8888F will ignore any parity error, which is detected on PCI bus interface.	0b
<5:3>	RO	Reserved	000b
<2>	RO	Enable IT8888F to act as a master on primary interface.	1b
<1>	RO	Downstream memory transaction enabling.	1b
<0>	RO	Downstream I/O transaction enabling.	1b

- **Status (STS) Register**

Address Offset: 06h - 07h

Default Value: 0280h

Access: Read Only, Write-1-to-Clear, SMB Load

Size: 16 bits

The status register is used to record status information for PCI bus related events. Reads to this register behave normally. Some bits with access attribute of W1C (Write-1-to Clear) means when writes to this register with a '1' to the corresponding bit location cause that bit to be reset.

Cfg_04h		Status / Command Register	
<31>	R/W1C	Set by IT8888F whenever it detects a parity error on PCI bus.	0b
<30>	R/W1C	Set by IT8888F whenever it asserts SERR#.	0b
<29>	R/W1C	Set by IT8888F whenever it, as a PCI bus master, terminates a transaction by signaling a Master Abort.	0b
<28>	R/W1C	Set by IT8888F whenever it, as a master, terminates a transaction by receiving a Target Abort.	0b
<27>	R/W1C	Set by IT8888F whenever it, as a target, terminates a transaction by signaling a Target Abort.	0b
<26:25>	R/L	Medium DEVSEL# timing for IT8888F as a target to respond to an access on PCI bus.	01b
<24>	R/W1C	Set by IT8888F when three conditions are met: 1) asserting PERR# itself or observing PERR# being asserted; 2) IT8888F acts as a bus master for the operation in which an error occurs; 3) Cfg_04h<6> is set.	0b
<23>	RO	Fast back-to-back capability (when IT8888F acts as a target).	1b
<22:16>	RO	Reserved	all zero













### 6.3.10 ROM / ISA Spaces and Timing Control

- **Timing Control Register**

Address Offset: 50h

Default Value: 001XX000b

Access: Read/Write, Read-only

Size: 8bits

This register is used for PCI Target I/F Response and SMB Boot Configuration.

Cfg_50h		ISA Spaces and Timing Control	
<7:6>	R/W	Palette Handling. 00b: iWiR. Ignore write, ignore Read access. 01b: sWiR. Snoop write, ignore Read access 10b: sW+R. Snoop write, positive decode read access 11b: +W+R. Positive decode write, positive decode read access	00b
<5>	R/W	I/O Port 00000080h Snoop Write (For POST code dump): 1b: Enable Snoop Write to Port 80h 0b: No response or do Subtractive decode for Port 80h	1b
<4>	RO	SMB_In_Progress, it shows the status of SM Bus Boot ROM being in progress. If TC is Pull/Up, this bit will be set to 1, and the SM-bus Boot ROM Configuration will be initiated. Once finished (get index= AAh), this bit will be cleared automatically.	Power On Strap value of TC
<3>	R/W	F-Segment BIOS access (of both 000FXXXXh & FFFFXXXXh): 1b: Positive decode with Fast DEVSEL# timing for F-segment 0b: No response or do Subtractive decode for F-segment	Power-On Strap value of BALE
<2>	R/W	Reserved, must be written with 0. For compatible test only. Enable Processing Delayed Transaction in PC/PCI DMA cycle: 1b: Delayed Transaction is enabled in PPDMA cycle if Cfg_50<1> is also enabled 0b: Delayed Transaction is disabled in PPDMA cycle, response as non-Delayed Transaction.	0b
<1>	R/W	Delayed Transaction in PIO cycle: 1b: Delayed Transaction is enabled. 0b: Delayed Transaction is disabled.	0b
<0>	R/W	Non-Claimed PCI cycle until Subtractive DEVSEL# timing: 1b: Responses as a Subtractive decode agent 0b: Still No response (only positive decode pre-defined space)	0b

- **Memory Top / IO Recovery Register**

Address Offset: 51h  
 Access: Read/Write

Default Value: F0h  
 Size: 8bits

This register is used for system BIOS to set extended memory top in 16MB space (below memory hole) and ISA I/O recovery time between two different PCI I/O accesses (i.e. no additional recovery wait state will be inserted during byte conversion).

Cfg_50h		ISA Spaces and Timing Control	
<15:12>	R/W	TOP of Memory boundary (Up to Memory Hole) in 1MB ~ 16MB location through PCI bus when DMA or ISA Master access: 0000b: 1M, 0001b: 2M, 0010b: 3M, 0011b: 4M, 0100b: 5M, 0101b: 6M, 0110b: 7M, 0111b: 8M, 1000b: 9M, 1001b: 10M, 1010b: 11M, 1011b: 12M, 1100b: 13M, 1101b: 14M, 1110b: 15M, 1111b: 16M.	1111b
<11:10>	R/W	16-bit I/O Access Recovery Time 00b:3.5 BCLK, 01b:4.5 BCLK, 10b:5.5 BCLK, 11b: 7.5 BCLK	00b
<9:8>	R/W	8-bit I/O Access Recovery Time 00b:3.5 BCLK, 01b:5.5 BCLK, 10b:7.5 BCLK, 11b:11.5 BCLK	00b

- **ISA Space Register**

Address Offset: 52h  
 Access: Read/Write

Default Value: FFh  
 Size: 8bits

This register is used for IT8888F to decide whether to forward DDMA or ISA Master cycle to PCI bus.

Cfg_50h		ISA Spaces and Timing Control	
<23>	R/W	KBC Space (0060/2/4/6) location when DMA or ISA Master access: 0b: @ ISA, Disable forwarding. 1b: @ PCI, then issue PCI master cycle.	1b
<22>	R/W	Memory Space of 000EXXXh location when DMA or ISA Master access: 0b: @ ISA, Disable forwarding. 1b: @ PCI, then issue PCI master cycle.	1b
<21>	R/W	Memory Space of 000D8000h~000DFFFFh location when DMA or ISA Master access: 0b: @ ISA, Disable forwarding. 1b: @ PCI, then issue PCI master cycle.	1b
<20>	R/W	Memory Space of 000D0000h~000D7FFFh location when DMA or ISA Master access: 0b: @ ISA, Disable forwarding. 1b: @ PCI, then issue PCI master cycle.	1b
<19>	R/W	Memory Space of 000C8000h~000CFFFFh location when DMA or ISA Master access: 0b: @ ISA, Disable forwarding. 1b: @ PCI, then issue PCI master cycle.	1b
<18>	R/W	Memory Space of 000C0000h~000C7FFFh (VGA BIOS) location when DMA or ISA Master access: 0b: @ ISA, Disable forwarding. 1b: @ PCI, then issue PCI master cycle.	1b
<17>	R/W	Memory Space of 000A0000h~000BFFFFh (Video Buffer) location when DMA or ISA Master access: 0b: @ ISA, Disable forwarding. 1b: @ PCI, then issue PCI master cycle.	1b
<16>	R/W	Memory Space of 00080000h~0009FFFFh location when DMA or ISA Master access: 0b: @ ISA, Disable forwarding. 1b: @ PCI, then issue PCI master cycle.	1b

- **ROM Decoding Register**

Address Offset: 53h  
 Access: Read/Write

Default Value: 01h  
 Size: 8bits

This register is used to generate ROM chip select.

Cfg_50h		ISA Spaces and Timing Control	
<31 >	R/W	Enable ROMCS# from Memory space FFFEXXXh (Top E-seg/4GB). 0b: Excludes FFFEXXXh; 1b: Includes FFFEXXXh	0b
<30 >	R/W	Enable ROMCS# from Memory space FFF80000h ~ FFFDFFFFh (Extended 384K of Top 4GB). 0b: Excludes; 1b: Includes	0b
<29 >	R/W	Enable ROMCS# from Memory space FFF00000h ~ FFF7FFFFh (1MB Extended 512K of Top 4GB). 0b: Excludes; 1b: Includes	0b
<28 >	R/W	Enable ROMCS# from Memory space 000EXXXh (E-seg/1MB) 0b: Excludes 000EXXXh; 1b: Includes 000EXXXh	0b
<27 >	R/W	Enable ROMCS# from Memory space 000DXXh (D-seg/1MB) 0b: Excludes 000DXXh; 1b: Includes 000DXXh	0b
<26 >	R/W	Enable ROMCS# from Memory space 000C8000h ~ 000CFFFFh 0b: Excludes 000C8000h ~ 000CFFFFh 1b: Includes 000C8000h ~ 000CFFFFh	0b
<25 >	R/W	Enable ROMCS# from Memory space 000C0000h ~ 000C7FFFh 0b: Excludes 000C0000h ~ 000C7FFFh 1b: Includes 000C0000h ~ 000C7FFFh	0b
<24 >	R/W	Flash ROM Write Protect (Mask ROMCS# and/or MEMW#) 0b: Enable Write to ROM; 1b: Write-Protect	1b



**• Misc. Control Register**

 Address Offset: 56h – 57h  
 Access: Read/Write

 Default Value: 8C00h  
 Size: 16bits

This register is used for PCI I/F Arbitration for DDMA/PPDMA and test and CLKRUN# function.

Cfg_54h		Retry/Discard Timers, Misc. Control Register	
<31>	R/W	Enable DDMA-Concurrent option 0: Disabled, Hold PCI bus through all DMA cycles 1: Enabled PCI & DMA / ISA-Master Accesses Concurrent.	1b
<30>	R/W	Enable Dummy PPDREQ# message for patching PC/PCI DMA undefined multiple DMA requests underrun/overflow. 0: Disabled, as PC/PCI DMA protocol not supports DMA devices multiple de-asserted simultaneously. 1: Enabled, IT8888F will issue a dummy PPDREQ# message (empty requests) to update the PPDREQ# decoding in core logic chipset.	0b
<29>	R/W	Enable Dummy FRAME# for some chipset arbitration patch when DDMA / ISA Master access with DDMA-Concurrent mode disabled. 0: Disabled, no Dummy FRAME#. 1: Enabled Dummy FRAME# for DDMA Verify and DDMA/ Master non-PCI access. (Available only when Cfg_54h<31>=0).	0b
<28>	R/W	SA[1:0] Toggling of ISA I/O cycles from the same one PCI I/O (due to multiple bytes). But when accessing the internal DDMA I/O ports, the SA[1:0] will be always increased for DMA device driver to program 32-bit Base_Address or 16-bit Word_Count registers): 0: Address Increased as ISA Memory mapped I/O cycles. 1: Address Fixed as the first ISA I/O for the successive I/O.	0b
<27>	R/W	Force PCI clock always running (whenever CLKRUN# sampled high, then drive low output for 2T): 1: Force PCICLK running. 0: Request PCI clock only for ISA master, DDMA and Interrupt.	1b
<26>	R/W	Enable ISA Bus Refresh Timer 1: Enable Processing Refresh every 15.36μs. (PCI clock will be kept running by asserting CLKRUN#.) 0: Disable Refresh Timer.	1b
<25>	R/W	Reserved for IC test only. Test SMB interface	0b
<24>	R/W	Reserved for IC test only. Test Refresh Address Counter	0b
<23>	R/W	Enable ISA Bus Master to update Flash ROM (when Cfh_50h<24> = 0) 0: Disabled, only PIO (CPU + PCI Master) and DMA cycle can write into ROM with control timing for WE#-Controlled Write Operation. 1: Enabled, and the control timing is used for Flash ROM CE#-Controlled Write Operation	0b

Cfg_54h		Retry/Discard Timers, Misc. Control Register	
<22>	R/W	Enable PCI Configure write operation to change the content of Subsystem Device/Vendor ID Register (Cfg_2Ch<31:0>). 0: Disabled, only SMB_ROM Configuring can update it. 1: Enabled. It is generally provided for optional device BIOS to change subsystem ID for its device.	0b
<21>	R/W	Mask IOCHCK# to report to SERIRQ coding 0: Unmasked, IOCHCK# status will be reflected in SERIRQ coding. 1: Masked, IOCHCK# will not be reflected in SERIRQ coding.	0b
<20>	R/W	Select the function of pin#138 to be NOGO or CLKRUN#: 0=NOGO, 1=CLKRUN#.	0b
<19>	R/W	Enable ISA IOCHCK# report (Cfg_54h<18>) to SERR#. 0=Disabled, 1=Enabled.	0b
<18>	R/W1C	Read 1 as the ISA IOCHCK# is asserted. This is the inverse state of the latched ISA IOCHCK# signal. Write 1 to clear.	0b
<17>	R/W	Enable checking PCI I/O Cycle Byte Lane Error (Cfg_54h<16>) and report to SERR#. 0=Disabled, 1=Enabled.	0b
<16>	R/W1C	Read 1 as the PCI I/O Cycle Byte Lane Error occurred. Write 1 to clear.	0b

### 6.3.12 Positively Decoded IO\_Space\_0 Register

Address Offset: 58h – 5Bh  
Access: Read/Write

Default Value: 00000000h  
Size: 32bits

This register is used for the configuration and the Positively Decoded I/O Space 0.

Cfg_58h		Positively Decoded IO_Space_0	
<31>	R/W	IO_Space_0 Enable: 1b: IT8888F will respond to IO_Space_0; 0b: No-response	0b
<30:29>	R/W	Decoding Speed for IO_Space_0: 00b: Subtractive speed    10b: Medium speed 01b: Slow speed         11b: Fast speed	00b
<28>	R/W	Alias Enable for IO_Space_0: 1b: Don't care A[15:10]; 0b: Fully decode	0b
<27>	RO	Reserved	0b
<26:24>	R/W	IO_Space_0 Size: 000b: 1 bytes    010b: 4 bytes    100b: 16 bytes    110b: 64 bytes 001b: 2 bytes    011b: 8 bytes    101b: 32 bytes    111b: 128 bytes	000b
<23:16>	RO	Reserved	00h
<15:0>	R/W	Base Address of IO_Space_0: A[15:0], with A[31:16]=0000h	0000h

**6.3.13 Positively Decoded IO\_Space\_1 Register**

 Address Offset: 5Ch – 5Fh  
 Access: Read/Write

 Default Value: 00000000h  
 Size: 32bits

This register used for configuration and the Positively Decoded I/O Space 1.

Cfg_5Ch		Positively Decoded IO_Space_1	
<31>	R/W	IO_Space_1 Enable: 1b: IT8888F will respond to IO_Space_1; 0b: No-response	0b
<30:29>	R/W	Decoding Speed for IO_Space_1: 00b: Subtractive speed    10b: Medium speed 01b: Slow speed            11b: Fast speed	00b
<28>	R/W	Alias Enable for IO_Space_1: 1b: Don't care A[15:10]; 0b: Fully decode	0b
<27>	RO	Reserved	0b
<26:24>	R/W	IO_Space_1 Size: 000b: 1 bytes    010b: 4 bytes    100b: 16 bytes    110b: 64 bytes 001b: 2 bytes    011b: 8 bytes    101b: 32 bytes    111b: 128 bytes	000b
<23:16>	RO	Reserved	00h
<15:0>	R/W	Base Address of IO_Space_1: A[15:0], with A[31:16]=0000h	0000h

**6.3.14 Positively Decoded IO\_Space\_2 Register**

 Address Offset: 60h – 63h  
 Access: Read/Write

 Default Value: 00000000h  
 Size: 32bits

This register is used for configuration and the Positively Decoded I/O Space 2.

Cfg_60h		Positively Decoded IO_Space_2	
<31>	R/W	IO_Space_2 Enable: 1b: IT8888F will respond to IO_Space_2; 0b: No-response	0b
<30:29>	R/W	Decoding Speed for IO_Space_2: 00b: Subtractive speed    10b: Medium speed 01b: Slow speed            11b: Fast speed	00b
<28>	R/W	Alias Enable for IO_Space_2: 1b: Don't care A[15:10]; 0b: Fully decode	0b
<27>	RO	Reserved	0b
<26:24>	R/W	IO_Space_2 Size: 000b: 1 bytes    010b: 4 bytes    100b: 16 bytes    110b: 64 bytes 001b: 2 bytes    011b: 8 bytes    101b: 32 bytes    111b: 128 bytes	000b
<23:16>	RO	Reserved	00h
<15:0>	R/W	Base Address of IO_Space_2: A[15:0], with A[31:16]=0000h	0000h

### 6.3.15 Positively Decoded IO\_Space\_3 Register

Address Offset: 64h – 67h  
 Access: Read/Write

Default Value: 00000000h  
 Size: 32bits

This register is used for configuration and the Positively Decoded I/O Space 3.

Cfg_64h		Positively Decoded IO_Space_3	
<31>	R/W	IO_Space_3 Enable: 1b: IT8888F will respond to IO_Space_3; 0b: No-response	0b
<30:29>	R/W	Decoding Speed for IO_Space_3: 00b: Subtractive speed    10b: Medium speed 01b: Slow speed            11b: Fast speed	00b
<28>	R/W	Alias Enable for IO_Space_3: 1b: Don't care A[15:10]; 0b: Fully decode	0b
<27>	RO	Reserved	0b
<26:24>	R/W	IO_Space_3 Size: 000b: 1 bytes    010b: 4 bytes    100b: 16 bytes    110b: 64 bytes 001b: 2 bytes    011b: 8 bytes    101b: 32 bytes    111b: 128 bytes	000b
<23:16>	RO	Reserved	00h
<15:0>	R/W	Base Address of IO_Space_3: A[15:0], with A[31:16]=0000h	0000h

### 6.3.16 Positively Decoded IO\_Space\_4 Register

Address Offset: 68h – 6Bh  
 Access: Read/Write

Default Value: 00000000h  
 Size: 32bits

This register is used for configuring and the Positively Decoded I/O Space 4.

Cfg_68h		Positively Decoded IO_Space_4	
<31>	R/W	IO_Space_4 Enable: 1b: IT8888F will respond to IO_Space_4; 0b: No-response	0b
<30:29>	R/W	Decoding Speed for IO_Space_4: 00b: Subtractive speed    10b: Medium speed 01b: Slow speed            11b: Fast speed	00b
<28>	R/W	Alias Enable for IO_Space_4: 1b: Don't care A[15:10]; 0b: Fully decode	0b
<27>	RO	Reserved	0b
<26:24>	R/W	IO_Space_4 Size: 000b: 1 bytes    010b: 4 bytes    100b: 16 bytes    110b: 64 bytes 001b: 2 bytes    011b: 8 bytes    101b: 32 bytes    111b: 128 bytes	000b
<23:16>	RO	Reserved	00h
<15:0>	R/W	Base Address of IO_Space_4: A[15:0], with A[31:16]=0000h	0000h

**6.3.17 Positively Decoded IO\_Space\_5 Register**

Address Offset: 6Ch – 6Fh  
 Access: Read/Write

Default Value: 00000000h  
 Size: 32bits

This register is used for configuration and the Positively Decoded I/O Space 5.

Cfg_6Ch		Positively Decoded IO_Space_5	
<31>	R/W	IO_Space_5 Enable: 1b: IT8888F will respond to IO_Space_5; 0b: No-response	0b
<30:29>	R/W	Decoding Speed for IO_Space_5: 00b: Subtractive speed    10b: Medium speed 01b: Slow speed            11b: Fast speed	00b
<28>	R/W	Alias Enable for IO_Space_5: 1b: Don't care A[15:10]; 0b: Fully decode	0b
<27>	RO	Reserved	0b
<26:24>	R/W	IO_Space_5 Size: 000b: 1 bytes    010b: 4 bytes    100b: 16 bytes    110b: 64 bytes 001b: 2 bytes    011b: 8 bytes    101b: 32 bytes    111b: 128 bytes	000b
<23:16>	RO	Reserved	00h
<15:0>	R/W	Base Address of IO_Space_5: A[15:0], with A[31:16]=0000h	0000h

**6.3.18 Positively Decoded Memory\_Space\_0 Register**

Address Offset: 70h – 73h  
Access: Read/Write

Default Value: 00000000h  
Size: 32bits

This register is used for configuration and the Positively Decoded Memory Space 0.

Cfg_70h		Positively Decoded Memory_Space_0	
<31>	R/W	Memory_Space_0 Enable: 1b: IT8888F will respond to Memory_Space_0; 0b: No-response	0b
<30:29>	R/W	Decoding Speed for Memory_Space_0: 00b: Subtractive speed    10b: Medium speed 01b: Slow speed            11b: Fast speed	00b
<28:27>	RO	Reserved	00b
<26:24>	R/W	Memory_Space_0 Size: 000b: 16KB    010b: 64KB    100b: 256KB    110b: 1MB 001b: 32KB    011b: 128KB    101b: 512KB    111b: 2MB	000b
<23:16>	R/W	High Page Base Address of Memory_Space_0: A[31:24]. IT8888F will relocate the access within Memory_Space_0 to ISA bus, but the A[31:24] will be ignored since ISA has SA[23:0] only.	00h
<15:0>	R/W	Low Base Address of Memory_Space_0: A[23:8]. Bits <15:6> are R/W as A[23:14]; Bits <5:0> are RO as 6'b000000.	0000h

**6.3.19 Positively Decoded Memory\_Space\_1 Register**

Address Offset: 74h – 77h  
Access: Read/Write

Default Value: 00000000h  
Size: 32bits

This register is used for configuration and the Positively Decoded Memory Space 1.

Cfg_74h		Positively Decoded Memory_Space_1	
<31>	R/W	Memory_Space_1 Enable: 1b: IT8888F will respond to Memory_Space_1; 0b: No-response	0b
<30:29>	R/W	Decoding Speed for Memory_Space_1: 00b: Subtractive speed    10b: Medium speed 01b: Slow speed            11b: Fast speed	00b
<28:27>	RO	Reserved	00b
<26:24>	R/W	Memory_Space_1 Size: 000b: 16KB    010b: 64KB    100b: 256KB    110b: 1MB 001b: 32KB    011b: 128KB    101b: 512KB    111b: 2MB	000b
<23:16>	R/W	High Page Base Address of Memory_Space_1: A[31:24]. IT8888F will relocate the access within Memory_Space_1 to ISA bus, but the A[31:24] will be ignored since ISA has SA[23:0] only.	00h
<15:0>	R/W	Low Base Address of Memory_Space_1: A[23:8]. Bits <15:6> are R/W as A[23:14]; Bits <5:0> are RO as 6'b000000.	0000h

**6.3.20 Positively Decoded Memory\_Space\_2 Register**

 Address Offset: 78h – 7Bh  
 Access: Read/Write

 Default Value: 00000000h  
 Size: 32bits

This register is used for configuration and the Positively Decoded Memory Space 2.

Cfg_78h		Positively Decoded Memory_Space_2	
<31>	R/W	Memory_Space_2 Enable: 1b: IT8888F will respond to Memory_Space_2; 0b: No-response	0b
<30:29>	R/W	Decoding Speed for Memory_Space_2: 00b: Subtractive speed    10b: Medium speed 01b: Slow speed            11b: Fast speed	00b
<28:27>	RO	Reserved	00b
<26:24>	R/W	Memory_Space_2 Size: 000b: 16KB    010b: 64KB    100b: 256KB    110b: 1MB 001b: 32KB    011b: 128KB    101b: 512KB    111b: 2MB	000b
<23:16>	R/W	High Page Base Address of Memory_Space_2: A[31:24]. IT8888F will relocate the access within Memory_Space_2 to ISA bus, but the A[31:24] will be ignored since ISA has SA[23:0] only.	00h
<15:0>	R/W	Low Base Address of Memory_Space_2: A[23:8]. Bits <15:6> are R/W as A[23:14]; Bits <5:0> are RO as 6'b000000.	0000h

**6.3.21 Positively Decoded Memory\_Space\_3 Register**

 Address Offset: 7Ch – 7Fh  
 Access: Read/Write

 Default Value: 00000000h  
 Size: 32bits

This register is used for configuration and the Positively Decoded Memory Space 3.

Cfg_7Ch		Positively Decoded Memory_Space_3	
<31>	R/W	Memory_Space_3 Enable: 1b: IT8888F will respond to Memory_Space_3; 0b: No-response	0b
<30:29>	R/W	Decoding Speed for Memory_Space_3: 00b: Subtractive speed    10b: Medium speed 01b: Slow speed            11b: Fast speed	00b
<28:27>	RO	Reserved	00b
<26:24>	R/W	Memory_Space_3 Size: 000b: 16KB    010b: 64KB    100b: 256KB    110b: 1MB 001b: 32KB    011b: 128KB    101b: 512KB    111b: 2MB	000b
<23:16>	R/W	High Page Base Address of Memory_Space_3: A[31:24]. IT8888F will relocate the access within Memory_Space_3 to ISA bus, but the A[31:24] will be ignored since ISA has SA[23:0] only.	00h
<15:0>	R/W	Low Base Address of Memory_Space_3: A[23:8]. Bits <15:6> are R/W as A[23:14]; Bits <5:0> are RO as 6'b000000.	0000h

**6.3.22 Undefined Register**

Address Offset: those not listed above  
 Access: Read Only

Default Value: 00000000h  
 Size: 32bits

These registers are reserved as read only.

<b>Cfg_XXh (else)</b>		<b>All other configuration registers in IT8888F</b>	
<31:0>	RO	Reserved	00000000h

#### 6.4 DDMA Slave Registers Description

Only one register Base address is dedicated to each DDMA slave channel, and unique 16-byte register spaces are allocated for each DDMA Slave channel. Below is the DDMA slave register description:

DDMA Slave Address	R/W	Register Name	IT8888F Operation
Channel_N Base Address + 0h	W	Transfer Base Address[7:0]	Write to 8237_8 or 8237_16 Base address register of Channel_N
Channel_N Base Address + 0h	R	Current Transfer Address[7:0]	Read from 8237_8 or 8237_16 Current address register of Channel_N
Channel_N Base Address + 1h	W	Transfer Base Address[15:8]	Write to 8237_8 or 8237_16 Base address register of Channel_N <sup>1</sup>
Channel_N Base Address + 1h	R	Current Transfer Address[15:8]	Read from 8237_8 or 8237_16 Current address register of Channel_N
Channel_N Base Address + 2h	W	Transfer Base Address[23:16]	Write to Low Page register of Channel_N
Channel_N Base Address + 2h	R	Current Transfer Address[23:16]	Read from Low Page register of Channel_N
Channel_N Base Address + 3h	W	Transfer Base Address[31:24]	Write to High Page register of Channel_N
Channel_N Base Address + 3h	R	Current Transfer Address[31:24]	Read from High Page register of Channel_N
Channel_N Base Address + 4h	W	Base Word Count[7:0]	Write to 8237_8 or 8237_16 Base Word Count register of Channel_N
Channel_N Base Address + 4h	R	Current Word Count[7:0]	Read from 8237_8 or 8237_16 Current Word Count register of Channel_N
Channel_N Base Address + 5h	W	Base Word Count[15:8]	Write to 8237_8 or 8237_16 Base Word Count register of Channel_N
Channel_N Base Address + 5h	R	Current Word Count[15:8]	Read from 8237_8 or 8237_16 Current Word Count register of Channel_N
Channel_N Base Address + 6h	W	Base Word Count[23:16]	No Operation
Channel_N Base Address + 6h	R	Current Word Count[23:16]	Read 00h
Channel_N Base Address + 7h	N/A	Reserved	No Operation

<sup>1</sup> DDMA Host should handle Byte-Flip-Flop pointer.

**DDMA Slave Registers Description (continued)**

<b>DDMA Slave Address</b>	<b>R/W</b>	<b>Register Name</b>	<b>IT8888F Operation</b>
Channel_N Base Address + 8h	W	Command	Write to 8237_8 or 8237_16 Command register
Channel_N Base Address + 8h	R	Status	Read from 8237_8or 8237_16 Status register and convert / duplicate data bits, depending on Channel_N information.
Channel_N Base Address + 9h	W	S/W DMA Request	Write to 8237_8 or 8237_16 Request register
Channel_N Base Address + 9h	R	Reserved	Read Data Undefined
Channel_N Base Address + Ah	N/A	Reserved	Ignore Write; Read Data Undefined
Channel_N Base Address + Bh	W	Mode	Write to 8237_8 or 8237_16 Mode register
Channel_N Base Address + Bh	R	Reserved	Read Data Undefined
Channel_N Base Address + Ch	N/A	Reserved	Ignore Write; Read Data Undefined
Channel_N Base Address + Dh	W	Master Clear	Write to 8237_8 or 8237_16 Master Clear register
Channel_N Base Address + Dh	R	Reserved	Read Data Undefined
Channel_N Base Address + Eh	N/A	Reserved	Ignore Write; Read Data Undefined
Channel_N Base Address + Fh	W	Multi-Channel Mask	Write to 8237_8 or 8237_16 Single Channel Mask register w/ shifting data bit<0> to bit<2> and converting Channel_N information to bit<1:0>
Channel_N Base Address + Fh	R	Multi-Channel Mask	Read from 8237_8or 8237_16 Single Channel Mask register and convert / duplicate data bits, depending on Channel_N information.

## 7. Characteristic

### Absolute Maximum Ratings\*

Applied Voltage ( $V_{CC}$ ).....	-0.3V to 6.0V
Input Voltage ( $V_I$ ).....	-0.3V to $V_{CC}+0.3V$
Output Voltage ( $V_O$ ).....	-0.3V to $V_{CC}+0.3V$
Storage Temperature ( $T_{STG}$ ).....	-40°C to 125°C

### \*Comments

Stresses above those listed under “Absolute Maximum Ratings” may cause permanent damage to the device. These are stress ratings only. Functional operation of this device at these or any other conditions above those indicated in “Recommended Operating Conditions” is not implied and exposure to absolute maximum rating conditions for extended periods may affect device reliability.

**Table 7-1. Recommended Operating Conditions**

Symbol	Parameter	Min.	Typical	Max.	Units
VCC3	Power Supply	3.0	3.3	3.6	V
VCC	Power Supply	4.75	5.0	5.25	V
$V_{IN}$	Input Voltage	0		VCC / VCC3	V
$T_{OPT}$	Operating Temperature	0	25	70	°C

### 7.1 DC Electrical Characteristics

**Table 7-2 General DC Characteristics**

Symbol	Parameter	Conditions	Min.	Typical	Max.	Units
$I_{IL}$	Input Low Current	no P/D or P/U	-1		1	$\mu A$
$I_{IH}$	Input High Current	no P/D or P/U	-1		1	$\mu A$
$I_{OZ}$	Tri-state Leakage Current		-10		10	$\mu A$
$I_{CC}$	Operating Current	from VCC source				mA
$I_{CC3}$	Operating Current	from VCC3 source				mA
$C_{IN}$	Input Capacitance			3		$\rho F$
$C_{OUT}$	Output Capacitance			3 to 6		$\rho F$
$C_{BID}$	Bi-directional buffer Capacitance			3 to 6		$\rho F$

**Table 7-3 DC Electrical Characteristics**  
 (T<sub>OPT</sub>=0°C~70°C, VCC3=3.0~3.6V, VCC=4.75~5.25V)

Symbol	Parameter	Conditions	Min.	Typical	Max.	Units
V <sub>IL</sub>	Input Low Voltage for 5V cell	TTL			0.8	V
V <sub>IL</sub>	Input Low Voltage for 3.3V cell	CMOS			0.3*VCC3	V
V <sub>IL</sub>	Schmitt Input Low Voltage	TTL		1.10		V
V <sub>IH</sub>	Input High Voltage for 5V cell	TTL	2.2			V
V <sub>IH</sub>	Input High Voltage for 3.3V cell	CMOS	0.7*VCC3			V
V <sub>IH</sub>	Schmitt Input High Voltage	TTL		1.87		V
V <sub>OL</sub>	Output Low Voltage for 5V cell				0.4	V
V <sub>OL</sub>	Output Low Voltage for 3.3V cell				0.4	V
V <sub>OH</sub>	Output High Voltage for 5V cell		3.5			V
V <sub>OH</sub>	Output High Voltage for 3.3V cell		2.3			V

## 7.2 AC Characteristics

**Table 7-4 AC Characteristics of PCI Interface Timing**  
 (VCC=5.0V±5%, VCC3=3.3V±5%, T<sub>a</sub>=0°C~70°C, C<sub>L</sub>=50pF<sup>2</sup>) unit: ns

Symbol	Parameter	Min.	Typical	Max.	Notes
t <sub>VALID_PCI</sub>	Valid output delay time				
t <sub>SETUP_PCI</sub>	Input setup time				
t <sub>HOLD_PCI</sub>	Input hold time				
t <sub>ON_PCI</sub>	Float to Active				
t <sub>OFF_PCI</sub>	Active to Float				

<sup>2</sup> All the pads loading are based on 50pF for Typical simulated values.

**Table 7-5 AC Characteristics of ISA Interface Timing (PIO Cycle)**

 (Measured in Design Simulation) unit: 1T=1 PCICLK period  $\geq$  30ns

In the following parameters, the LA[23:20] signals are replaced by SA[23:20] to simplify descriptions.

Symbol	Parameter	Typical	Notes
$t_{BCLK}$	BCLK frequency	$\leq 8.25$	MHz (=PCICLK/4)
$t_{L\_BCLK}$	BCLK low period	$\geq 2T$	1T=1 PCICLK period
$t_{H\_BCLK}$	BCLK high period	2T	
$t_{H\_BALE}$	BALE high period in PIO mode	2T	
$t_{OS\_LA\_BALE}$	SA[23:2] valid to BALE de-asserted	$\geq 4T$	
$t_{OS\_LA\_M}$	SA[23:2] valid to MEMR#/MEMW# asserted	$\geq 4T$	16-bit memory access
		$\geq 6T$	8-bit memory access
$t_{OS\_LA\_IO}$	SA[23:2] valid to IOR#/IOW# asserted	$\geq 6T$	16-/8-bit I/O access
$t_{OS\_SA\_M}$	SA[1:0], SBHE# valid to MEMR#/MEMW# asserted	2T	16-bit memory access
		4T	8-bit memory access
$t_{OS\_SA\_IO}$	SA[1:0], SBHE# valid to IOR#/IOW# asserted	4T	16-/8-bit I/O access
$t_{OH\_A}$	SA[23:0], SBHE# hold after command de-asserted	$\geq 2T$	all PIO access
$t_{W\_M}$	MEMR#/MEMW# low width	8T	16-bit access w/o NOWS#
		18T	8-bit access w/o NOWS#
		$\geq 4T$	16-bit access w/ NOWS#
		$\geq 6T$	8-bit access w/ NOWS#
$t_{W\_IO}$	IOR#/IOW# low width	6T	16-bit access
		18T	8-bit access w/o NOWS#
		$\geq 6T$	8-bit access w/ NOWS#
$t_{OS\_SD}$	SD[15:0] valid to MEMW#/IOW# asserted	0T	16-bit memory write
		2T	else
$t_{OH\_SD}$	SD[15:0] hold/float after MEMW#/IOW# de-asserted	2T	all PIO write access
$t_{OH\_CMD}$	command hold from IOCHRDY	$\geq 4T$	all PIO write access

**Table 7-6 AC Characteristics of ISA Interface Timing (DMA Cycle)**

 (Measured in Design Simulation) unit: 1T=1 PCICLK period  $\geq$  30ns

In the following parameters, the LA[23:20] signals are replaced by SA[23:20] to simplify descriptions.

Symbol	Parameter	Typical	Notes
<b>DDMA Mode</b>			
$t_{DD\_AEN\_DACK}$	AEN asserted to DACKn# asserted	0T	DACK[7:5]#
		4T	DACK[3:0]#
$t_{DD\_DACK\_AEN}$	DACKn# de-asserted to AEN de-asserted	0T	DACK[7:5]#
		4T	DACK[3:0]#
$t_{DD\_DACK\_IOR}$	DACKn# asserted to IOR# asserted	6T	
$t_{DD\_DACK\_IOW}$	DACKn# asserted to IOW# asserted	14T	
$t_{DD\_DACK\_M}$	DACKn# asserted to MEMR#/MEMW# asserted	14T	Memory space on ISA
$t_{DD\_PAGE\_M}$	Page Address valid to MEMR#/MEMW# asserted	14T	SA[23:17/16]
$t_{DD\_SA\_M}$	Base Address valid to MEMR#/MEMW# asserted	10T	SA[16/15:0]
$t_{DD\_M\_SA}$	Address hold after MEMR#/MEMW# de-asserted	4T	SA[23:0]
$t_{DD\_W\_R}$	IOR#/MEMR# hold after MEMW#/IOW# de-asserted	2T	
$t_{DD\_OS\_SD}$	SD[15:0] setup to IOW# de-asserted	8T	Memory space on PCI
$t_{DD\_OH\_SD}$	SD[15:0] hold/float after MEMW#/IOW# de-asserted	4T	
$t_{DD\_W\_IOR}$	IOR# width	$\geq$ 26T	Memory space on PCI
		30T	Memory space on ISA
$t_{DD\_W\_IOW}$	IOW# width	$\geq$ 16T	Memory space on PCI
		24T	Memory space on ISA
$t_{DD\_W\_MEMR}$	MEMR# width	26T	Memory space on ISA
$t_{DD\_W\_MEMW}$	MEMW# width	20T	Memory space on ISA
$t_{DD\_OS\_TC}$	TC valid to IOR#/IOW# de-asserted	22/28T	
$t_{DD\_OH\_TC}$	TC hold after IOR#/IOW# de-asserted	4/6T	

**Table 7-6 AC Characteristics of ISA Interface Timing (DMA Cycle) (continued)**  
 (Measured in Design Simulation) unit: 1T=1 PCICLK period  $\geq$  30ns

Symbol	Parameter	Typical	Notes
<b>PC/PCI DMA Mode</b>			
$t_{PP\_SU\_IOR}$	PPDMA I/O cycle start to IOR# asserted	$\geq 7T$	
$t_{PP\_SU\_IOW}$	PPDMA I/O cycle start to IOW# asserted	$\geq 13/9T$	Normal/Type-F DMA
$t_{PP\_HD\_IOR}$	IOR# de-asserted to PPDMA I/O cycle end	6T	DACKn#/AEN hold until PPDGNT# de-asserted
$t_{PP\_HD\_IOW}$	IOW# de-asserted to PPDMA I/O cycle end	8T	
$t_{PP\_OS\_SD}$	SD[15:0] setup to IOW# asserted (falling edge)	8/4T	Normal/Type-F DMA
$t_{PP\_OH\_SD}$	SD[15:0] hold/float after IOW# de-asserted	8T	
$t_{PP\_W\_IOR}$	IOR# width	26/6T	Normal/Type-F DMA
$t_{PP\_W\_IOW}$	IOW# width	18/6T	Normal/Type-F DMA
$t_{PP\_OSR\_TC}$	TC valid to IOR # de-asserted	28/8T	Normal/Type-F DMA
$t_{PP\_OSW\_TC}$	TC valid to IOW# de-asserted	26/10T	Normal/Type-F DMA
$t_{PP\_OH\_TC}$	TC hold after IOR#/IOW# de-asserted	4/6T	

**Table 7-7 AC Characteristics of SMB Interface Timing**  
 (refer to Figure 7-23, Measured in Design Simulation) unit:  $\mu$ s

Symbol	Parameter	Typical	Notes
$t_{SCLK}$	SCLK frequency	$\leq 86.8$	KHz (= PCICLK/384)
$t_{L\_SCLK}$	SCLK low period	5.76	$\mu$ s (= 192 PCI clocks)
$t_{H\_SCLK}$	SCLK high period	5.76	$\mu$ s
$t_{SU\_STA}$	Start condition setup time	5.76	$\mu$ s
$t_{HD\_STA}$	Start condition hold time	5.76	$\mu$ s
$t_{SU\_STOP}$	Stop condition setup time	5.76	$\mu$ s
$t_{OS\_SDATA}$	SDATA output setup time	2.38	$\mu$ s (= 96 PCI clocks)
$t_{OH\_SDATA}$	SDATA output hold time	2.38	$\mu$ s
$t_{IS\_SDATA}$	SDATA input setup time	-2.3	$\mu$ s
$t_{IH\_SDATA}$	SDATA input hold time	-2.3	$\mu$ s

### 7.3 Waveforms

In the following waveforms, the LA[23:20] signals symbol are replaced by SA[23:20] to simplify drawings.

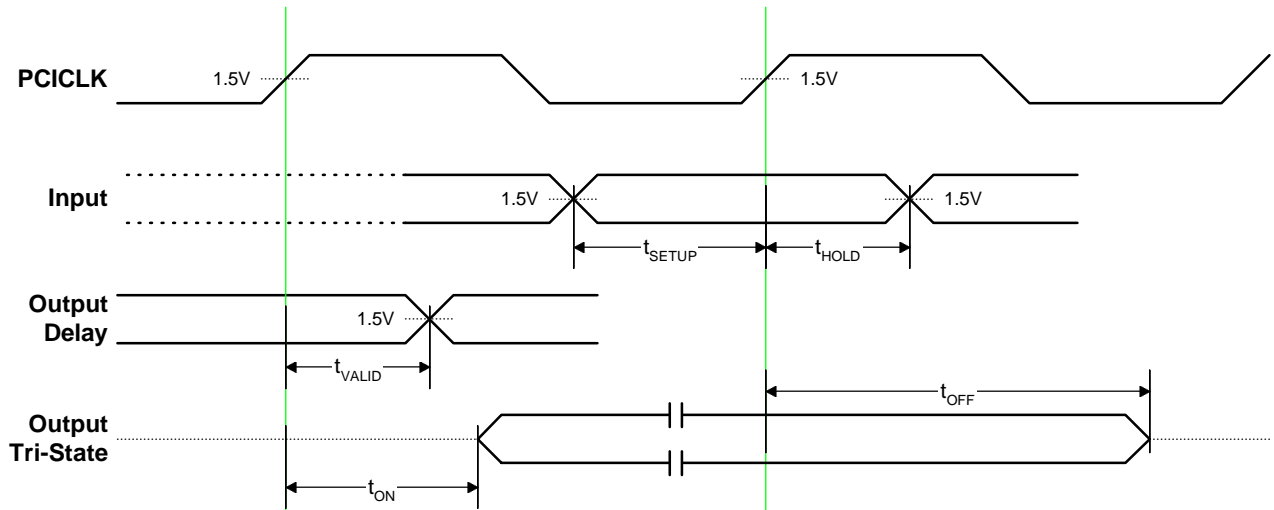

Figure 7-1 PCI Bus Interface Timing

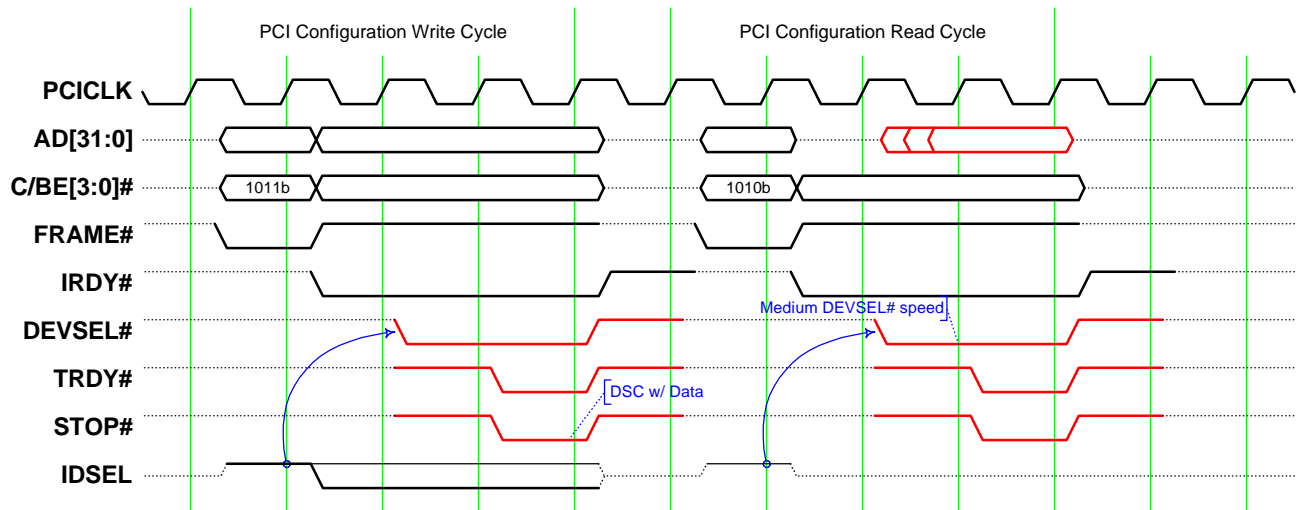
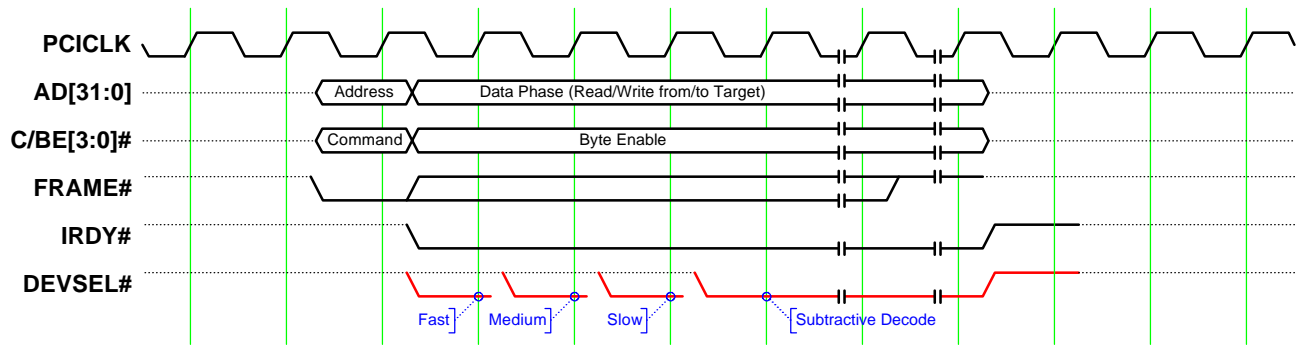
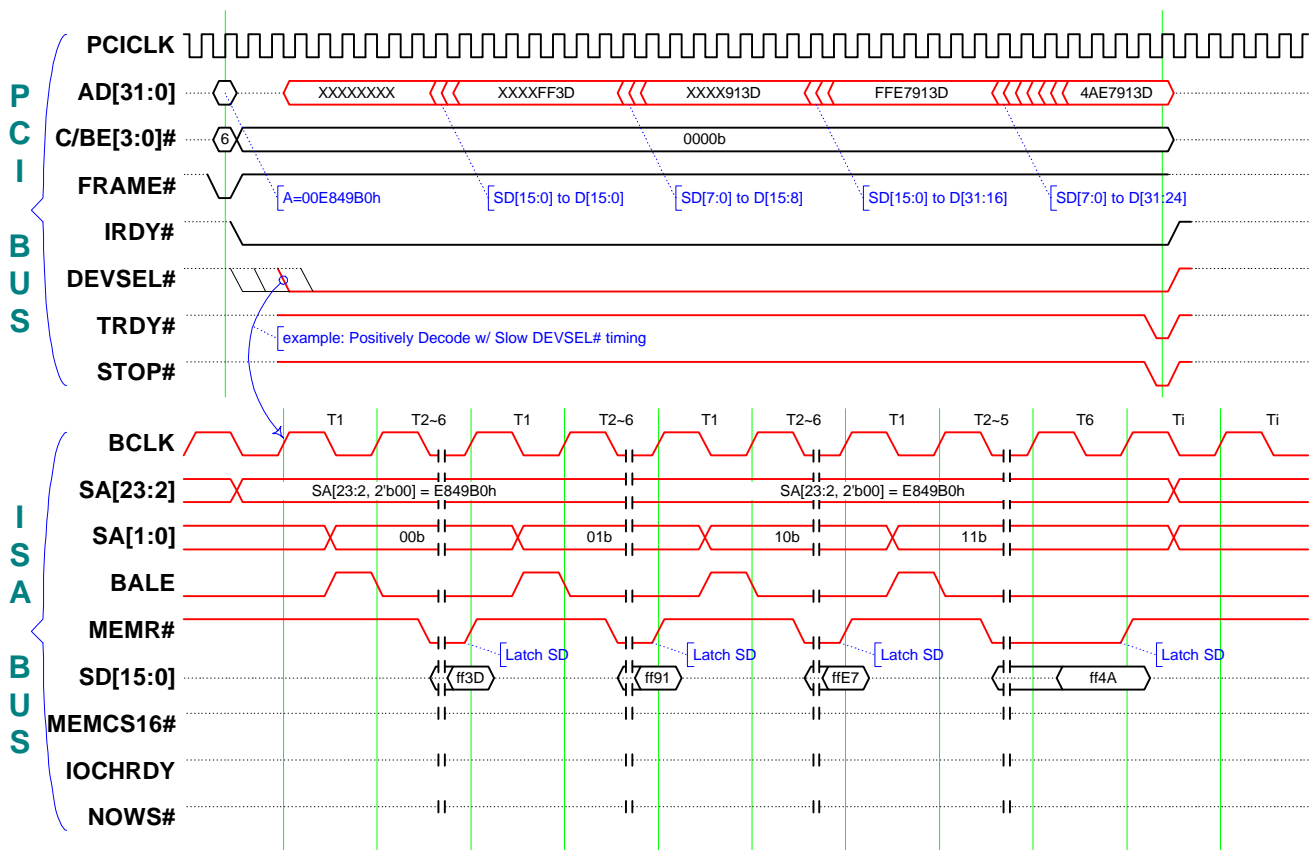

Figure 7-2 PCI Configuration Write / Read Cycle



**Figure 7-3 DEVSEL# Decoding Speed**



**Figure 7-4 PCI Memory Read from ISA Device when Delayed Transaction is disabled**

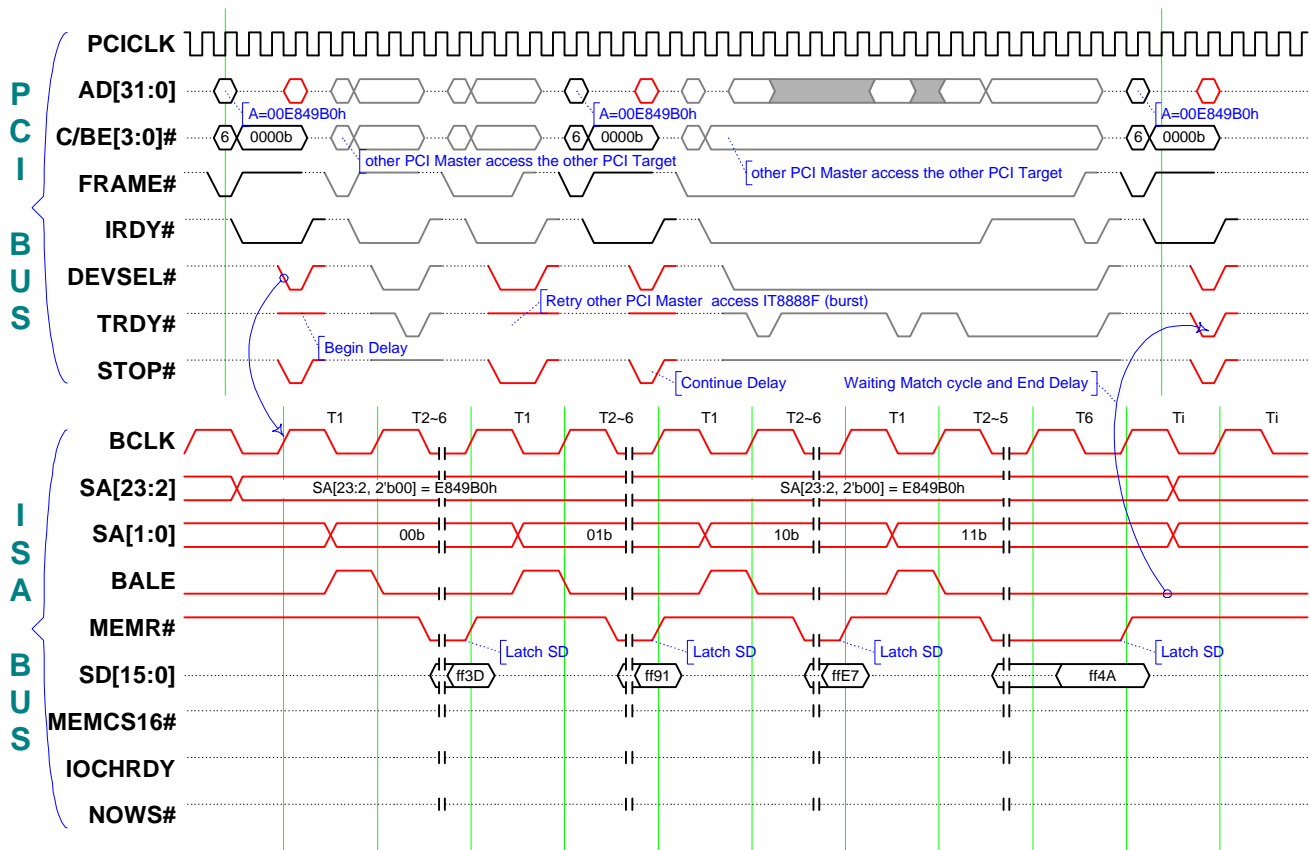
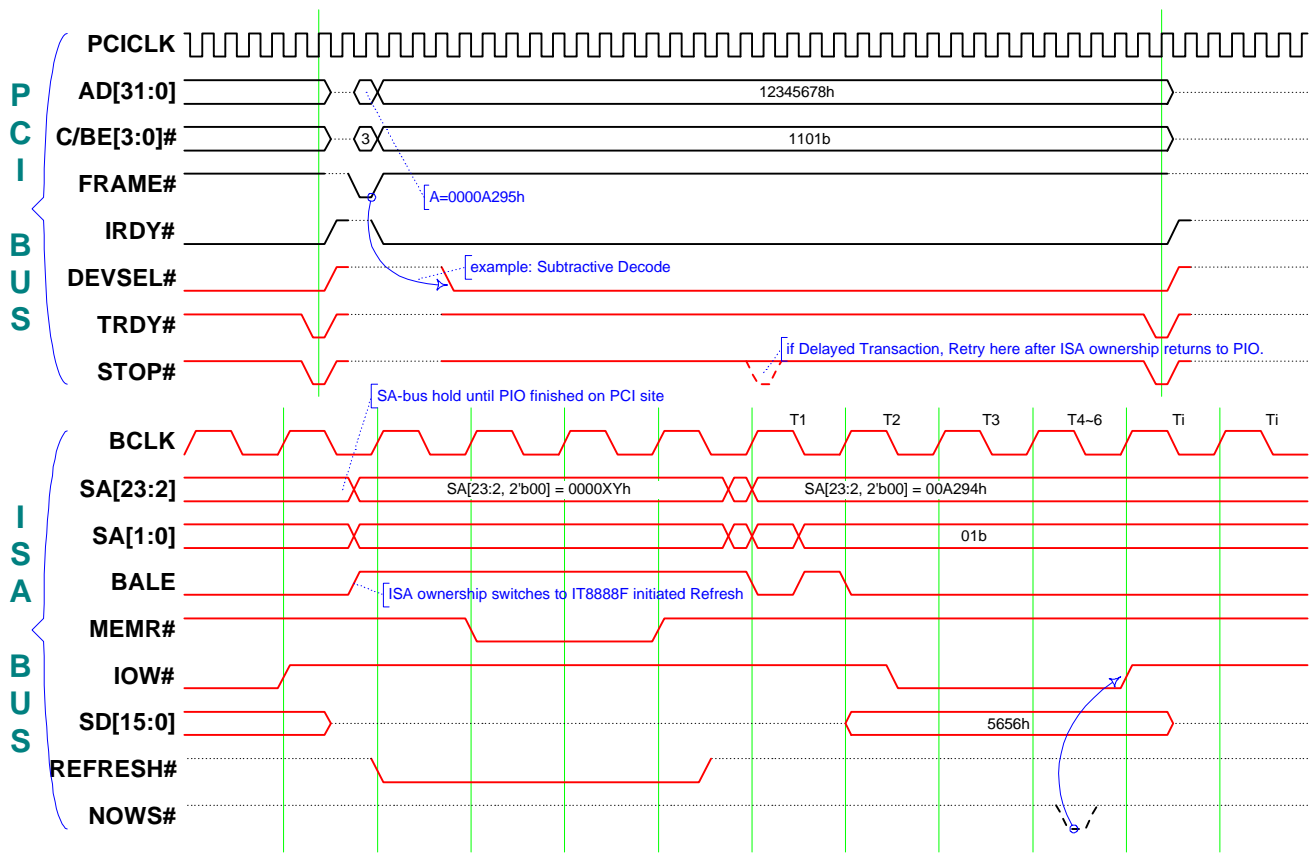
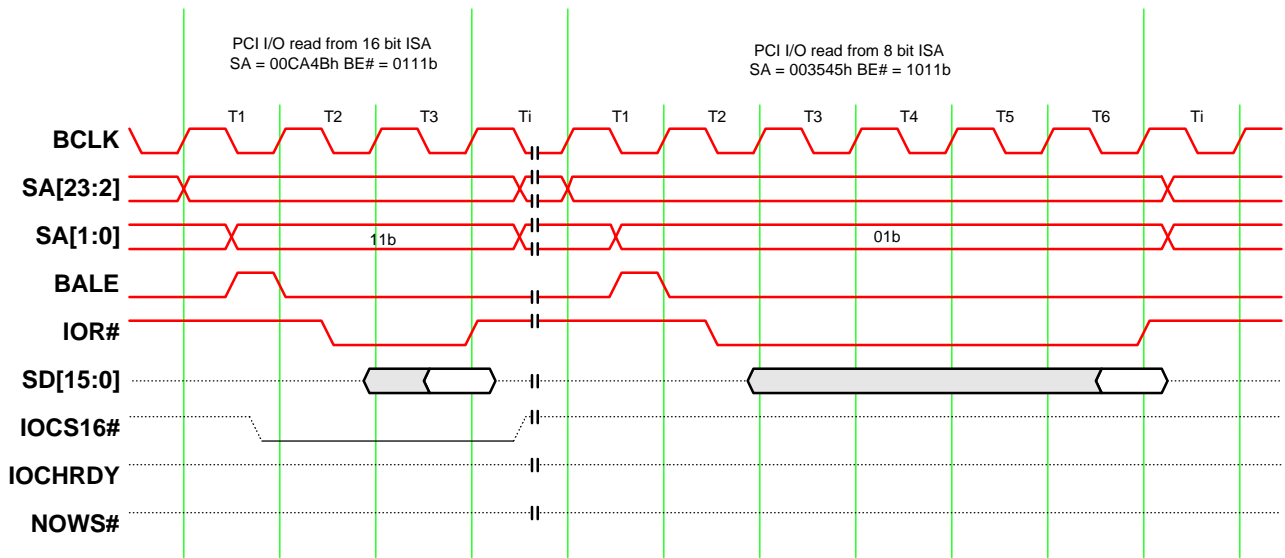

Figure 7-5 PCI Memory Read from ISA Device when Delayed Transaction is enabled



**Figure 7-6 IT8888F Initiated Refresh Cycle**



**Figure 7-7 PCI I/O Read from ISA device**

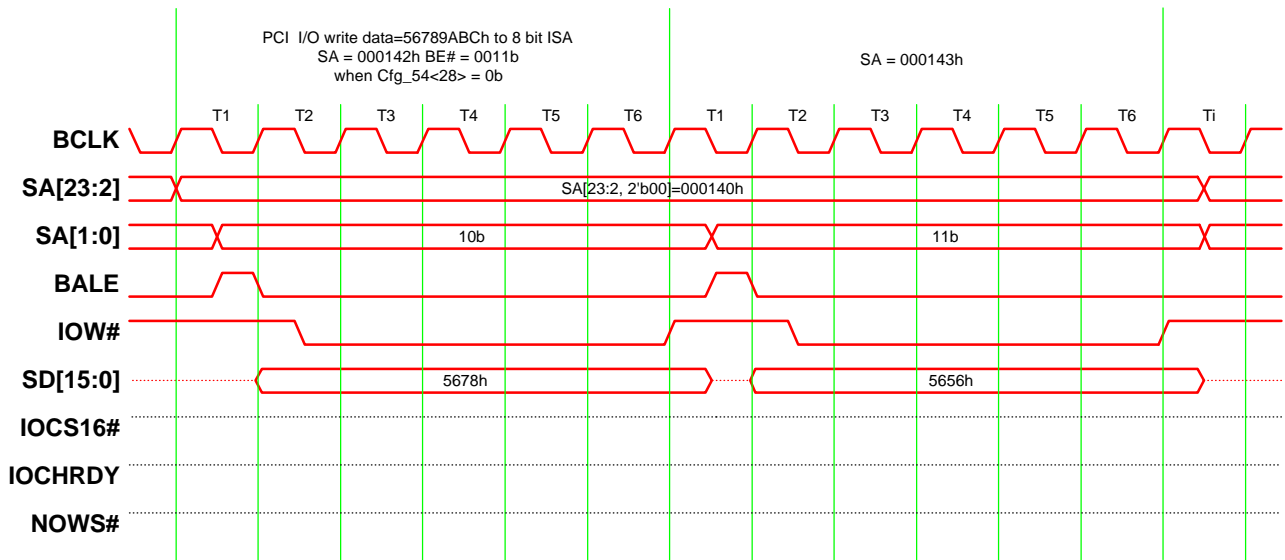

**Figure 7-8 PCI I/O Write to 8-bit ISA Device when Cfg\_54<28>=0b**

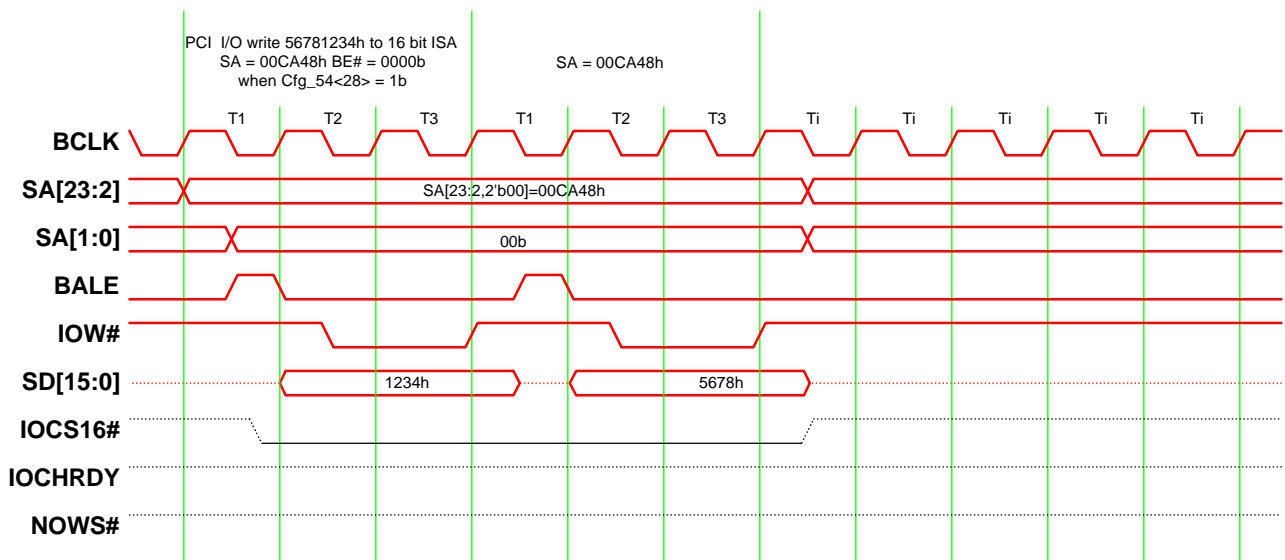

**Figure 7-9 PCI I/O Write to 16-bit ISA Device when Cfg\_54<28>=1b**

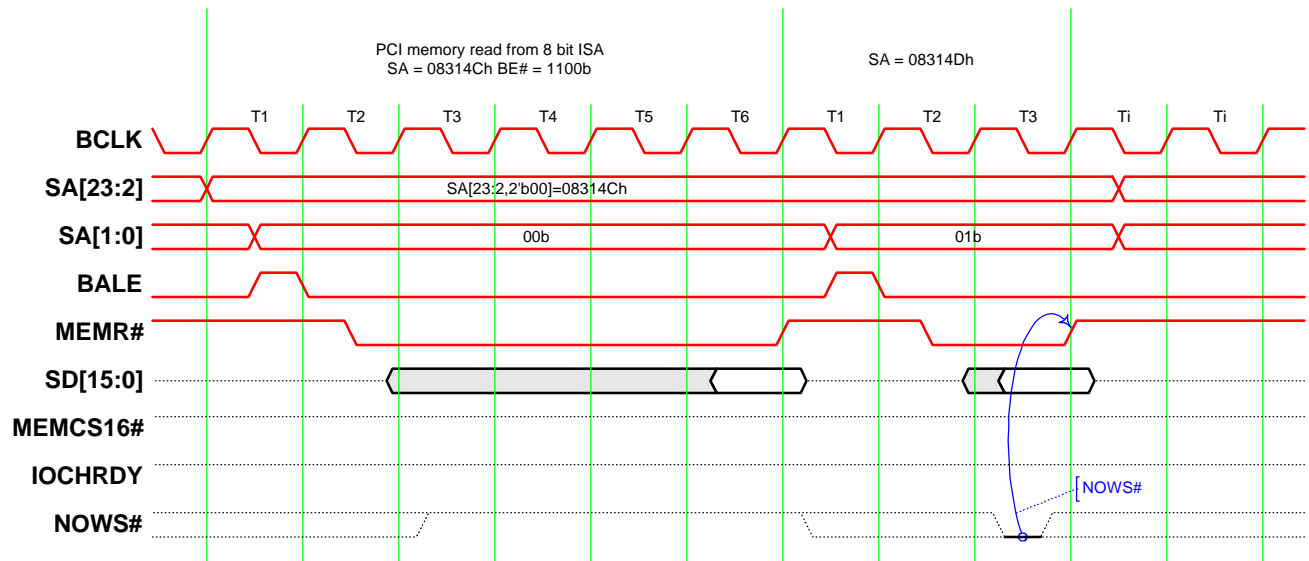

Figure 7-10 PCI Memory Read from 8-bit ISA Device

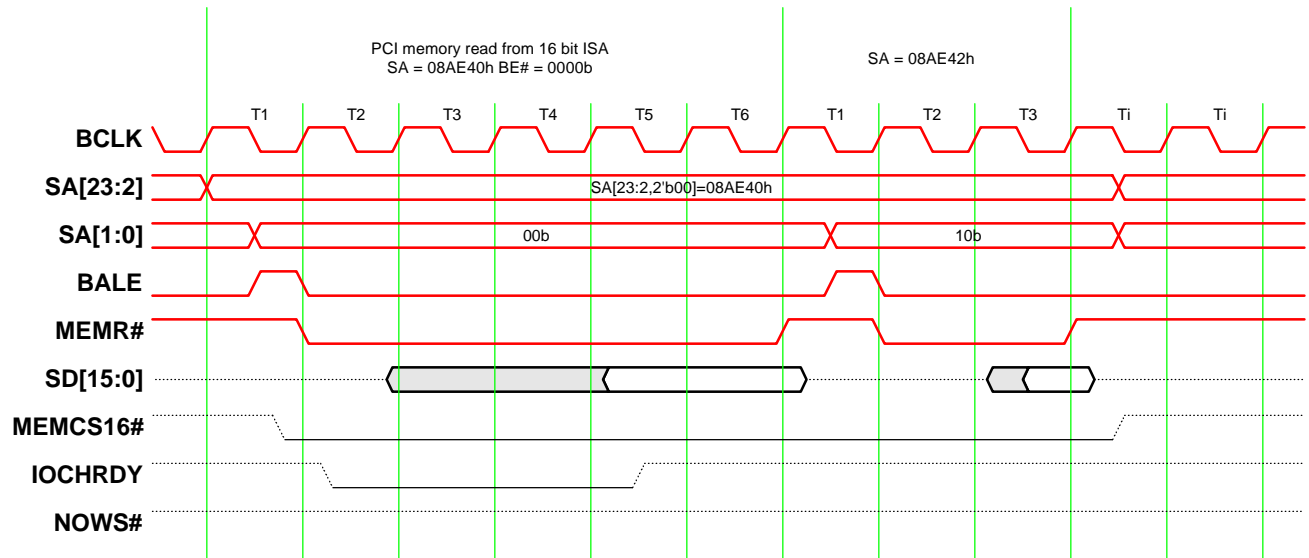
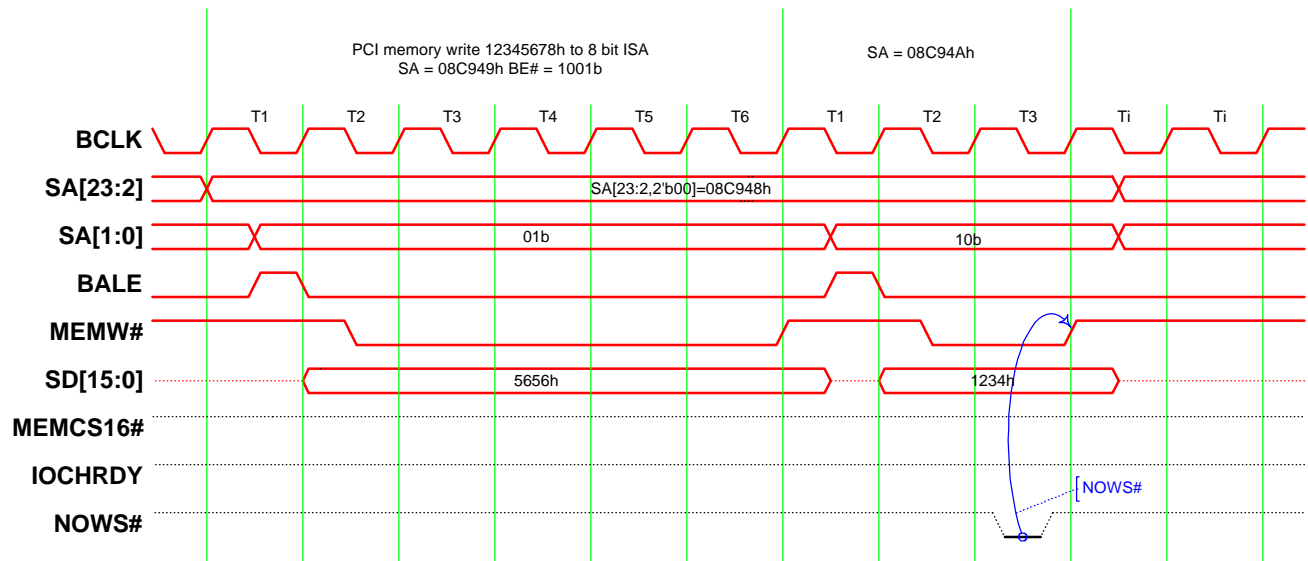
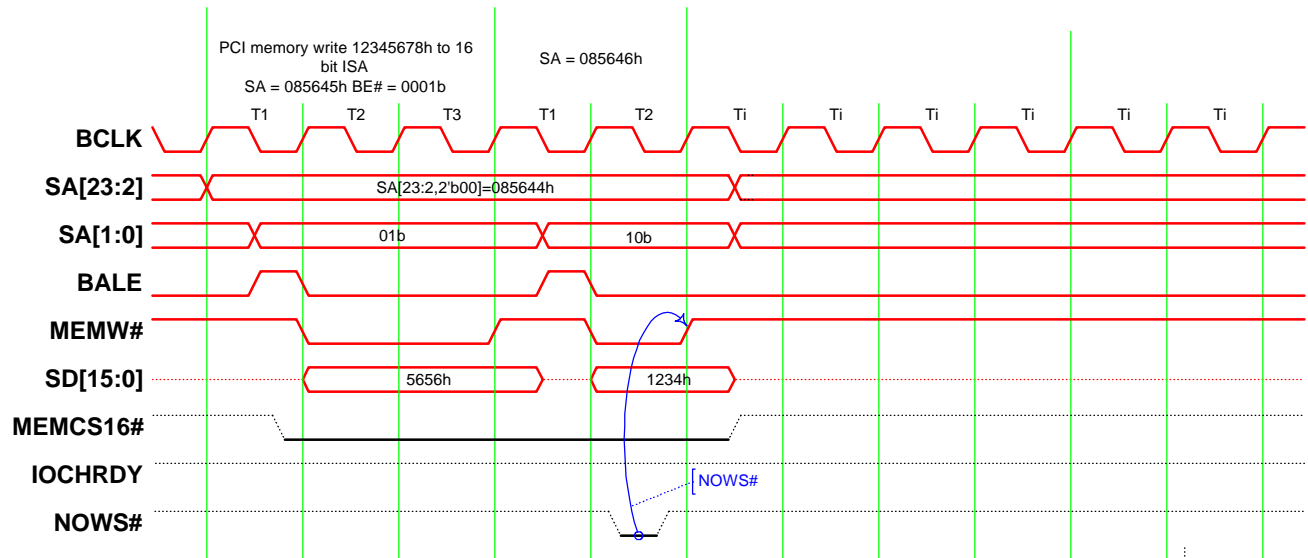

Figure 7-11 PCI Memory Read from 16-bit ISA Device



**Figure 7-12 PCI Memory Write to 8-bit ISA Device**



**Figure 7-13 PCI Memory Write to 16-bit ISA Device**

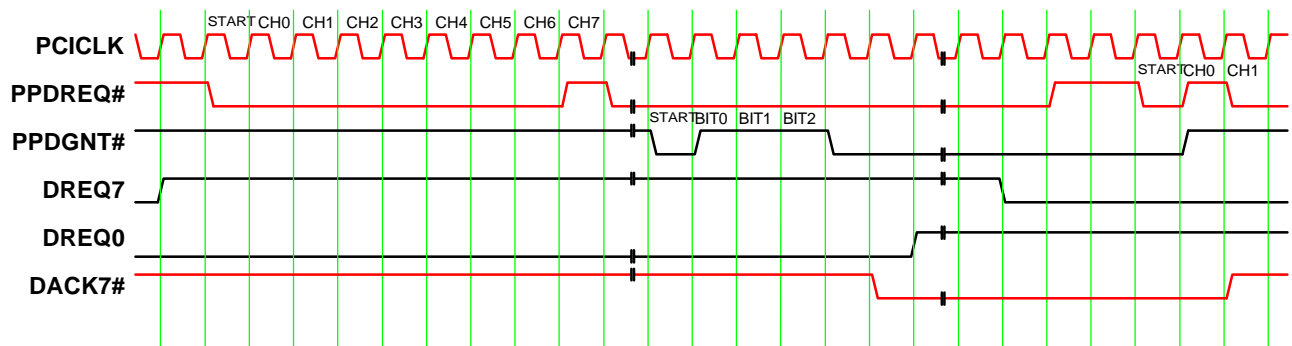

Figure 7-14 DREQn/DACKn# Coding in PC/PCI DMA Function

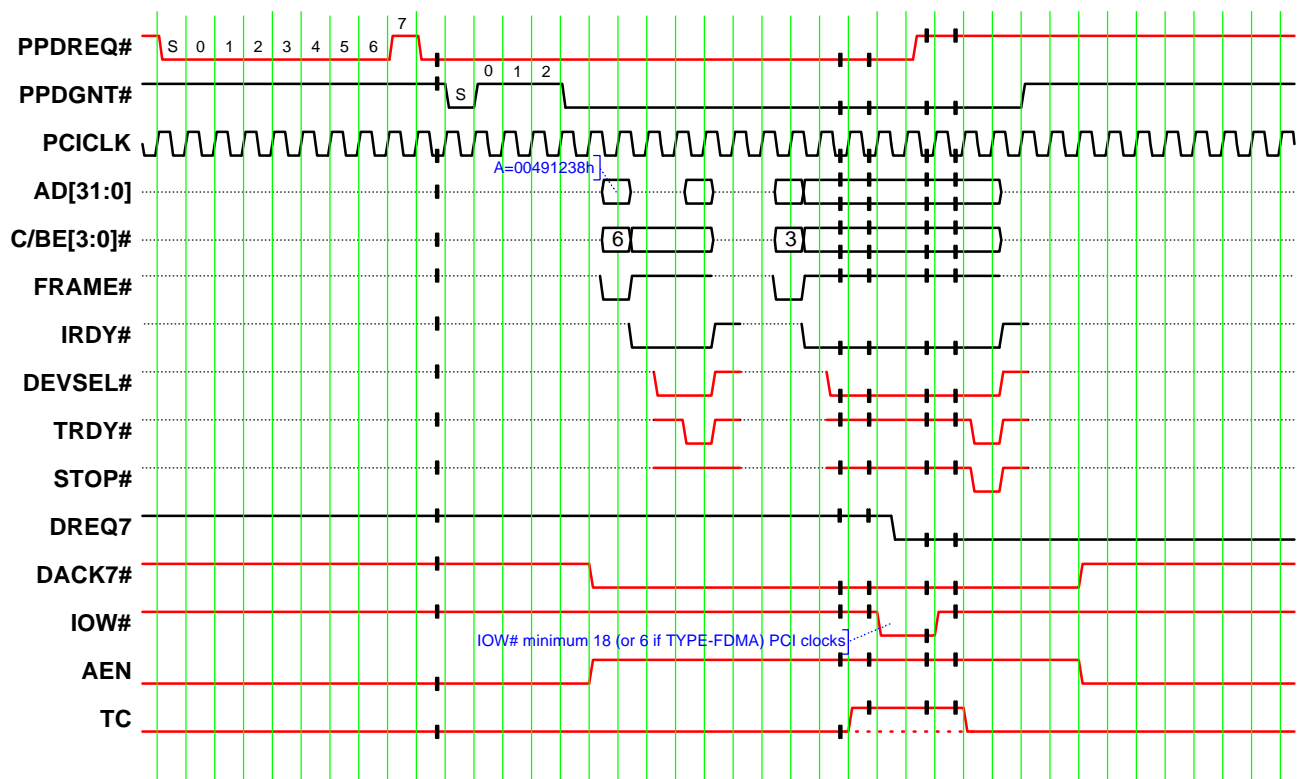

Figure 7-15 DMA Read Operation in PC/PCI DMA (Memory Access to PCI with TC)

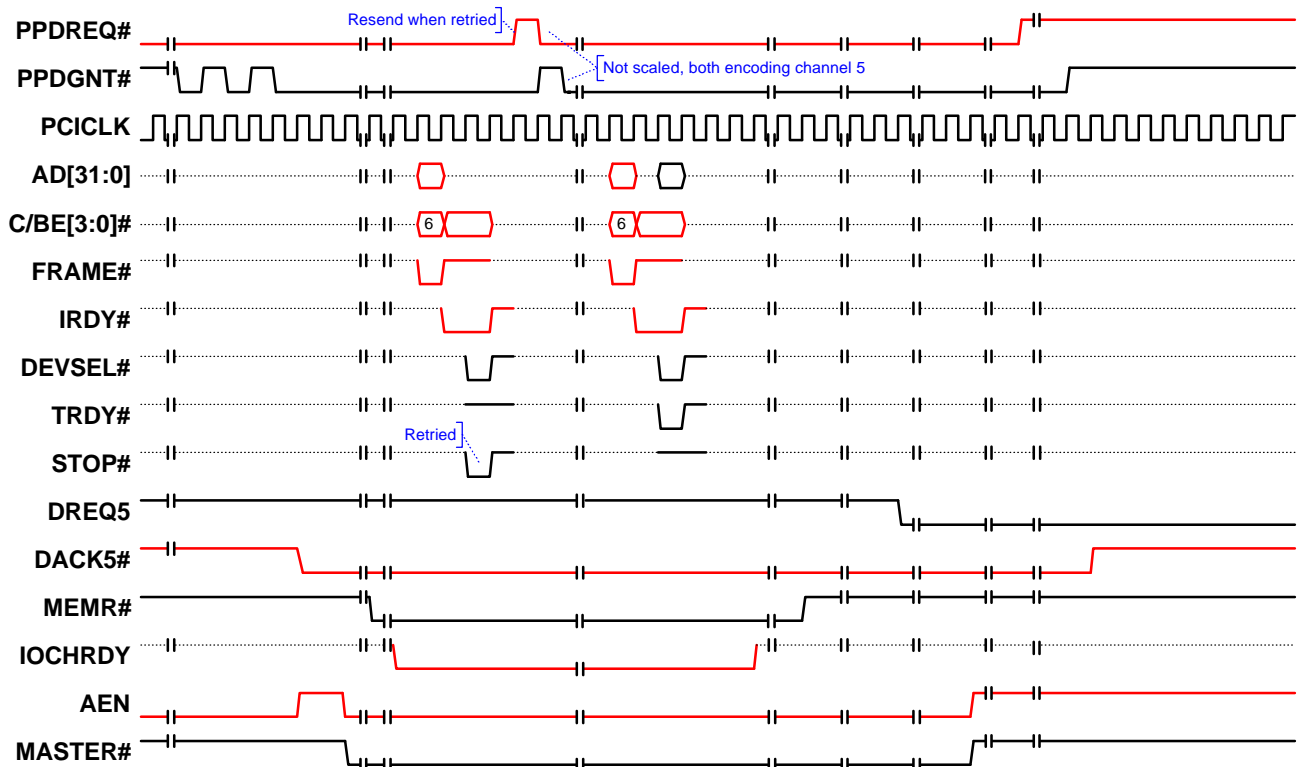

Figure 7-16 ISA Master Memory Read from PCI in PC/PCI DMA (Retried and Normal Termination)

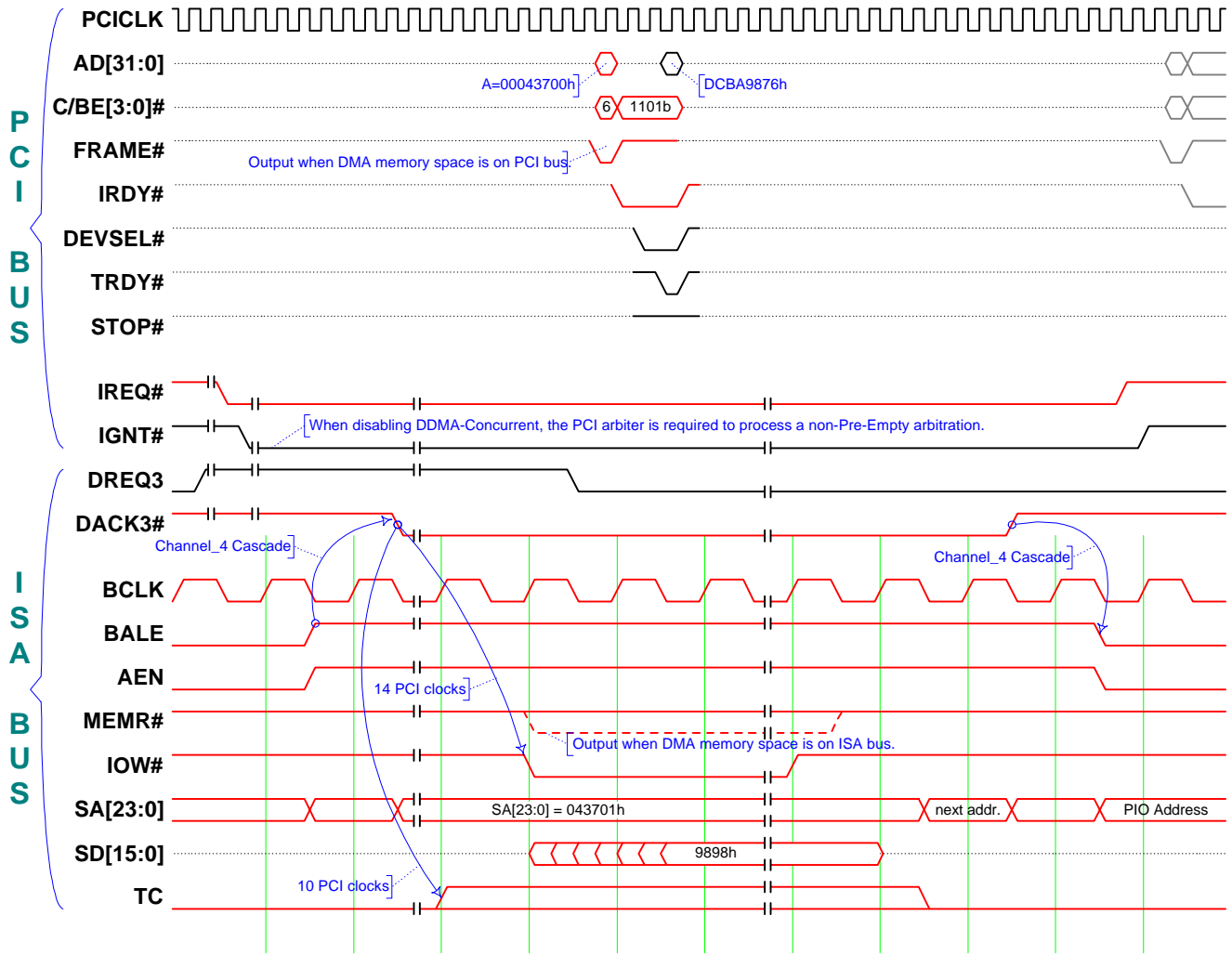
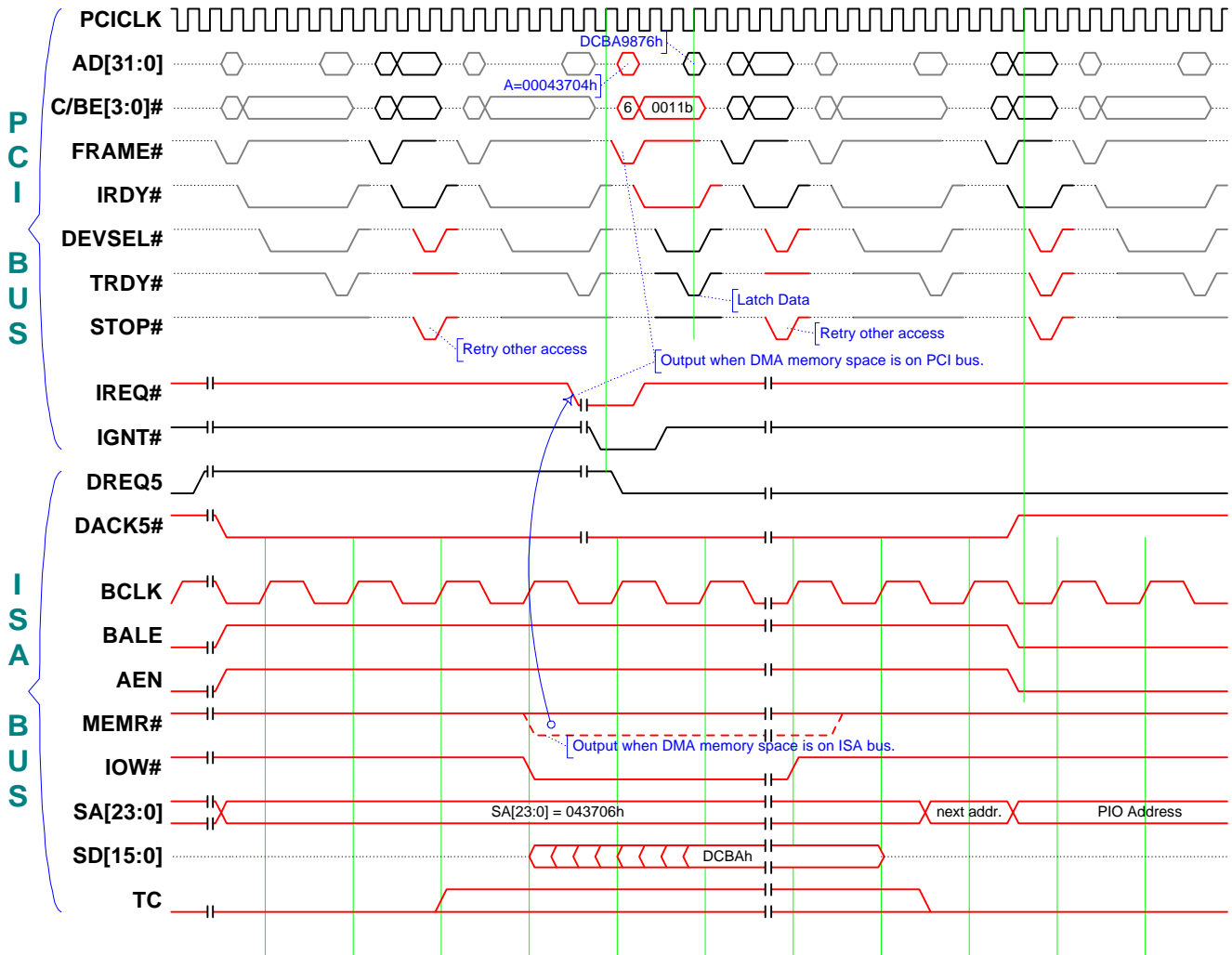
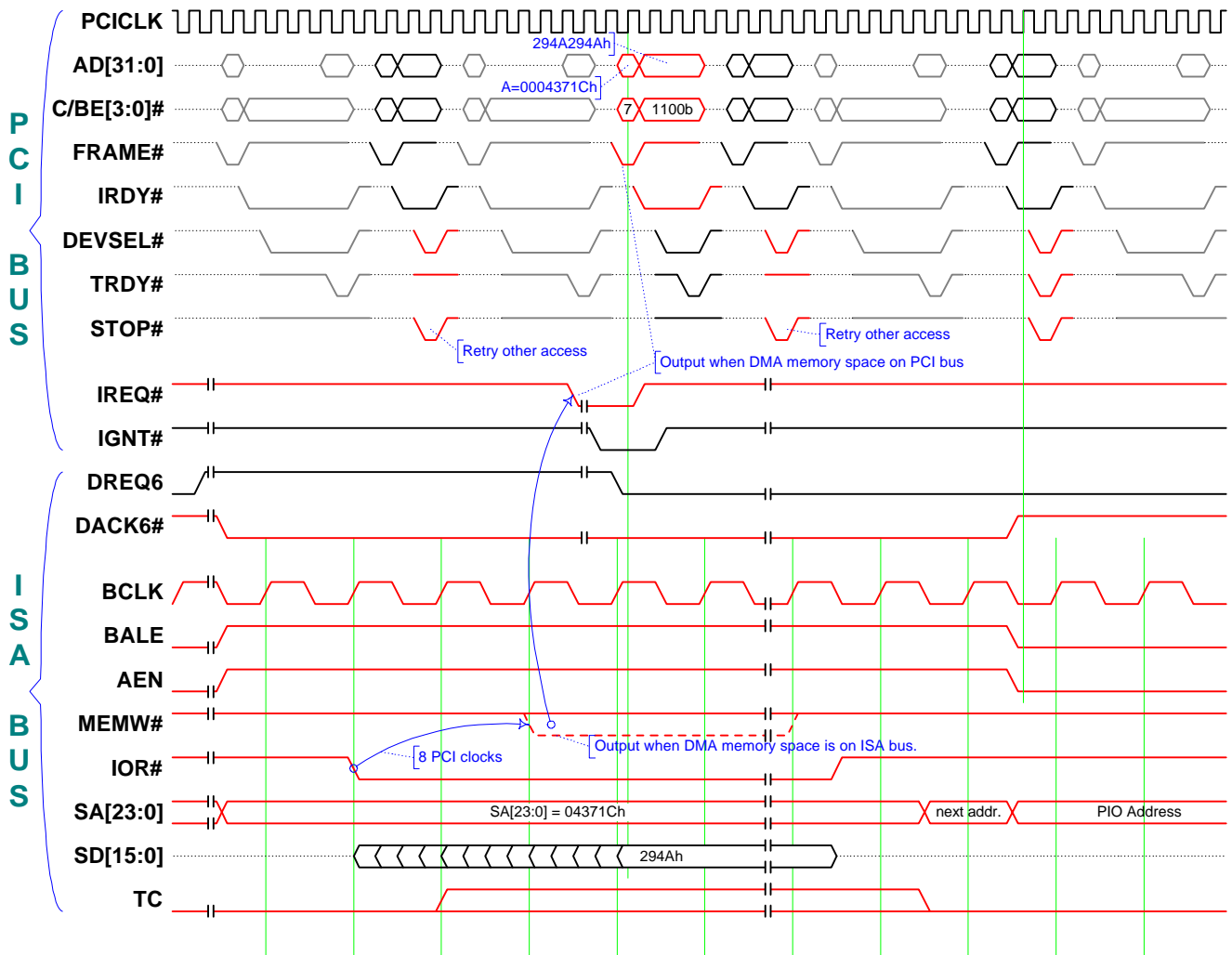

Figure 7-17 DMA Read Operation in DDMA (Memory Access to PCI when DDMA-Concurrent is disabled.)



**Figure 7-18 DMA Read Operation in DDMA (Memory Access to PCI when both Delayed-Transaction and DDMA-Concurrent are enabled.)**



**Figure 7-19 DMA Write Operation in DDMA (Memory Access to PCI when both Delayed-Transaction and DDMA-Concurrent are enabled.)**

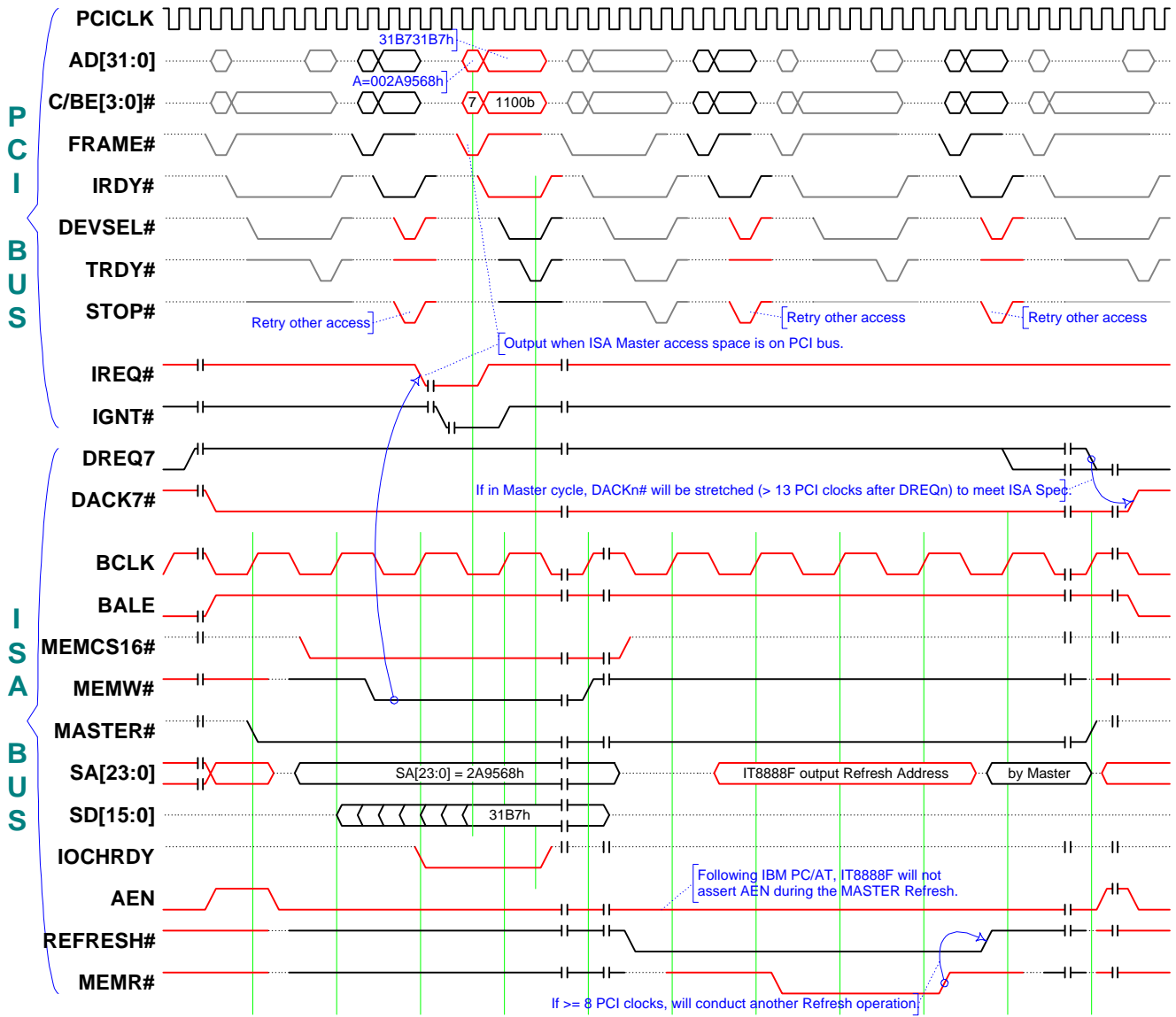

**Figure 7-20 ISA Master Write and Master-Initiated-Refresh Operation in DDMA (Memory Access to PCI when both Delayed-Transaction and DDMA-Concurrent are enabled.)**

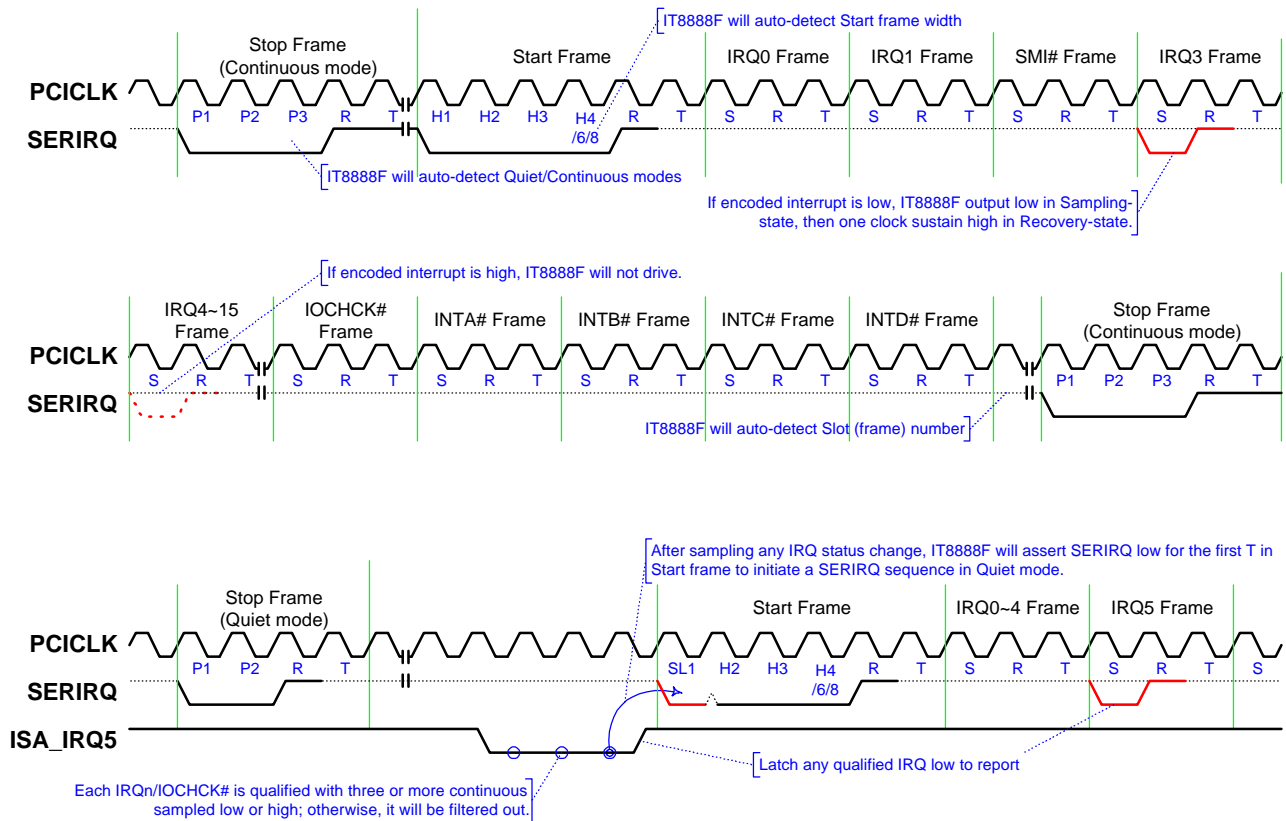

**Figure 7-21 Serialized IRQ Coding**

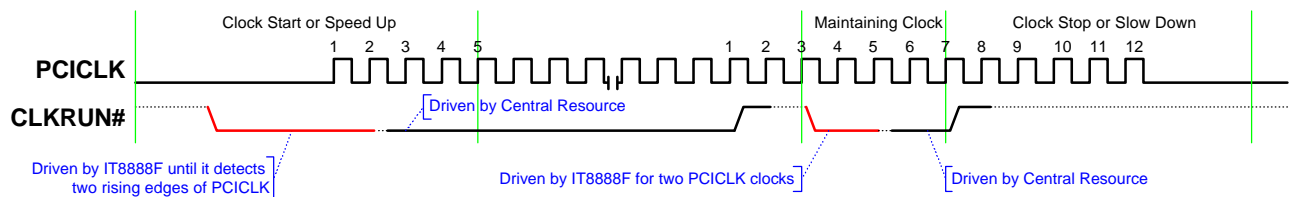

**Figure 7-22 CLKRUN# Operation**

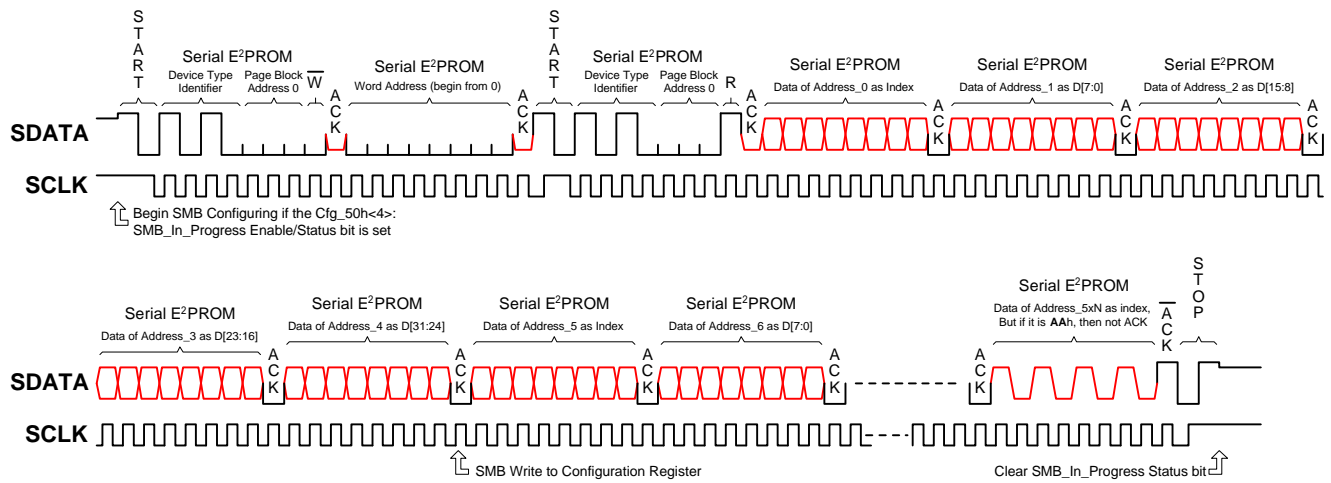

**Figure 7-23 SMB Serial E<sup>2</sup>PROM Configuration Programming**

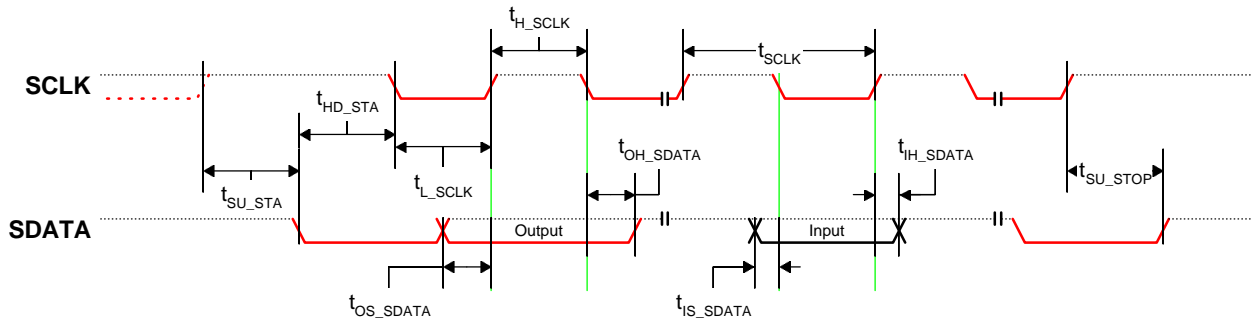
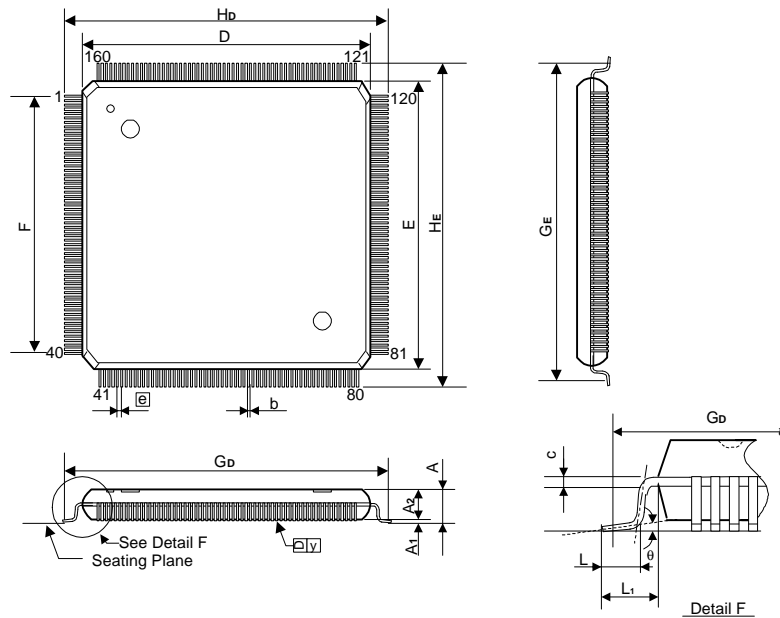

**Figure 7-24 SMB Serial E<sup>2</sup>PROM Interface Timing**

## 8. Package Information

### PQFP 160L Outline Dimensions

unit: inches/mm



Symbol	Dimensions in inch	Dimensions in mm
A	0.145 Max.	3.68 Max.
A <sub>1</sub>	0.004 Min.	0.10 Min.
A <sub>2</sub>	0.127±0.005	3.23±0.13
B	0.012 <sup>+0.004</sup> -0.002	0.30 <sup>+0.10</sup> -0.05
c	0.006 <sup>+0.004</sup> -0.002	0.15 <sup>+0.10</sup> -0.05
D	1.102±0.005	28.00±0.13
E	1.102±0.005	28.00±0.13
[e]	0.026±0.006	0.65±0.15
F	0.998 NOM.	25.35 NOM.
G <sub>D</sub>	1.197 NOM.	30.40 NOM.
G <sub>E</sub>	1.197 NOM.	30.40 NOM.
H <sub>b</sub>	1.228±0.012	31.20±0.30
H <sub>E</sub>	1.228±0.012	31.20±0.30
L	0.031±0.008	0.80±0.20
L <sub>1</sub>	0.063±0.008	1.60±0.20
y	0.004 Max.	0.10 Max.
θ	0°~10°	0°~10°

**Note:**

1. The dimensions D & E don't include resin fins.
2. Dimensions F, G<sub>D</sub>, G<sub>E</sub> are for PC Board surface mount pad pitch design reference only.
3. All dimensions are based on metric system.

**9. Ordering Information**

<b>Part No.</b>	<b>Package</b>
IT8888F	160 PQFP